

Schöne Schattenseiten.
Stay cool in the shade.

SKIROSOL SRCK 610

Climatic sensor



Anweisungen und Hinweise für den Installateur
Instructions et recommandations pour l'installateur
Istruzioni ed avvertenze per l'installatore
Instructions and warnings for the fitter
Instrucciones y advertencias para el instalador
Instructies en waarschuwingen voor de installateur



www.stobag.com



STOBAG
Premium Swiss Quality 

Wichtige Hinweise:

Für Installation, Wartung und Reparatur des Produktes wenden Sie sich bitte an fachkundiges, technisches Personal, das dieselben unter genauer Beachtung der gültigen Gesetzesvorschriften auszuführen hat.

⚠ Die Anleitungen genau lesen und prüfen, welche Motoren oder Steuerungen für die Wetterwächter SKIROSOL SRCK 610 geeignet sind. Jeder andere Einsatz ist unsachgemäss und verboten.

1) Beschreibung des Produkts

Der Wetterwächter SKIROSOL SRCK 610 misst die Windgeschwindigkeit in km/h und die Sonnenlichtstärke in Klux.

Er kann zum Steuern von Motoren und Steuerungen benutzt werden und ermöglicht es durch eine Funksteuerung, die Bewegung von Markisen, Jalousien und ähnlichem je nach gemessenen Wetterbedingungen zu automatisieren. Im Fall einer Markise wird das Überschreiten des Ansprechwerts SONNE zum Beispiel das Ausfahren der Markise verursachen, und das Überschreiten des Ansprechwerts WIND das Einfahren. Die Steuerbefehle werden per Funk gesendet, daher sind die einzigen auszuführenden Anschlüsse die der elektrischen Linie (siehe "Installation").

SKIROSOL SRCK 610 ist mit einer kleinen Programmier- oder Übertragungstaste (🔑) (Abb. 1, Detail B) und einem mehrfarbigen Leuchtmelder (LED ☉) (Abb. 1, Detail C) ausgestattet; weiterhin ist eine akustische Meldevorrichtung (Beep 🎵) vorhanden.

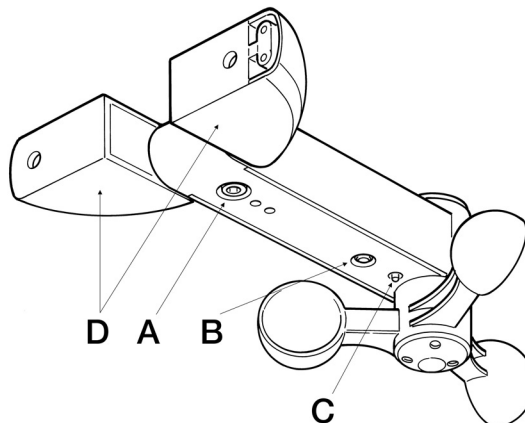

1.1) Regeln der Steuervorrichtung

SKIROSOL SRCK 610 misst die Geschwindigkeit des WINDES und die Stärke der SONNE; wenn der Wert die programmierte Grenze überschreitet, wird ein Steuerbefehl zu den Motoren oder Steuerungen gesendet, wie hier folgend genauer angegeben:

Wind: Wenn der Ansprechwert „WIND“ mindestens 3 Sekunden lang überschritten wird, sendet er einen „Anstiegsbefehl“, mit der Taste ▲ auf den Fernbedienungen gleichwertig. Beim Überschreiten der Schwelle wird die LED rot und während der Sendung des Steuerbefehls erfolgt ein Blinken der LED mit ROTEM Licht.

Sonne: Wenn der Ansprechwert „SONNE“ mindestens 2 Minuten lang überschritten wird, sendet er einen „Abstiegsbefehl“, mit der Taste ▼ auf den Fernbedienungen gleichwertig. Beim Überschreiten der Schwelle wird die LED GRÜN und während der Sendung des Steuerbefehls erfolgt ein Blinken der LED mit GRÜNEM Licht.

Prioritäten: Werden beide Ansprechwerte überschritten, so hat „WIND“ nach einem Sicherheitsgrundsatz gegenüber „SONNE“ den Vorrang. Erst nachdem „WIND“ seit mindestens 2 Minuten wieder unter dem Ansprechwert ist, kann „SONNE“ je nach ihrer Regel eingreifen.

Jeder Steuerbefehl wiederholt sich periodisch, bis der Ansprechwert nicht mehr überschritten ist.

SKIROSOL SRCK 610 überträgt weiterhin die gemessenen Daten, wie Geschwindigkeit des WINDS in km/h, Lichtstärke der SONNE in KLux, Vorhandensein von REGEN*, TEMPERATUR*, FEUCHTIGKEIT*.

(* = nur für die Versionen mit jeweiligem Sensor)

2) Installation

Vor der Installation wird eine Überprüfung der Funkreichweite empfohlen, da dicke Mauern und/oder andere Vorrichtungen, die auf derselben Frequenz arbeiten, die Reichweite stark reduzieren können. Für die Überprüfung, eine provisorische Prüfung vornehmen (siehe "Prüfung") und sich zuerst in die Nähe der Automatisierung, dann in die Nähe der endgültigen Installationsstelle begeben. Obwohl die Reichweite unter guten Bedingungen auf freiem Feld 100-200 m sein kann, sollten unter Berücksichtigung der Schutzfunktion 20-30 m nicht überschritten werden. Weiterhin sollte geprüft werden, dass keine anderen Vorrichtungen vorhanden sind, die eine weitere Reduzierung der Reichweite verursachen können, da sie auf derselben Frequenz arbeiten und ständig senden, wie Alarmer, Kopfhörer, usw. Damit der Wetterwächter richtig funktioniert, muss er in der Nähe der Jalousie und in einer Zone angebracht werden, in der er Wind und Sonne ausgesetzt ist.

Für die Installation, auf die Abbildungen 2, 3, 4 und 7 Bezug nehmen, dabei die Befestigungsschraube (Abb. 1, Detail A) nicht stark anziehen.

⚠ Da SKIROSOL SRCK 610 mit Netzspannung gespeist ist, sollte er an einer nur schwer zugänglichen Stelle angebracht werden.

3) Elektrische Anschlüsse

Das Produkt muss an eine 230Vac Versorgung (Version SKIROSOL SRCK 610) oder an eine 120Vac Versorgung (Version SKIROSOL SRCK 610-V1) ohne Verbindung zur Erde angeschlossen werden, siehe Abb. 5, 6 und 7. Nach der Verdrahtung die Deckel des Befestigungsbügels gut schliessen (Abb. 1, Detail D).

4) Prüfung

Wenn der Wächter mit Spannung versorgt wird, erfolgen folgende Handlungen:





- akustische Einschaltmeldung (4 Bieptöne )
- mehrmaliges Blinken mit ROTEM Licht (vorprogrammiert = 3  = eingestellter Ansprechwert für WIND, dann mehrmaliges Blinken mit GRÜNEM Licht (vorprogrammiert = 3  = eingestellter Ansprechwert für SONNE).

Tabelle "A"	Einschalten	Beispiel
1.	Sobald die Steuerung mit Spannung versorgt ist, wird man 4 Bieptöne hören.	
2.	Anzeige des Ansprechwerts WIND durch mehrmaliges Blinken mit ROTEM Licht.	
3.	Anzeige des Ansprechwerts SONNE durch mehrmaliges Blinken mit GRÜNEM Licht.	

Für die Übereinstimmung der Anzahl an Blinkvorgängen und den Ansprechwerten wird auf die Tabellen B1 und B2 verwiesen.

In der nachfolgenden Beschreibung bezieht man sich auf einen Motor für Markisen, dieselben Verfahren können aber auch für die anderen Fälle angewendet werden. Um die korrekte Installation des Wächters zu überprüfen, nach folgenden Schritten vorgehen.

4.1) Speicherung des Codes

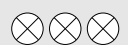











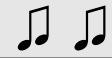



Damit die vom Wächter gesendeten Steuerbefehle Wirkung auf die Motoren und/oder Steuerungen haben, muss der Code wie in einer Fernbedienung gespeichert werden, da jede Fernbedienung vom Empfänger durch einen unterschiedlichen "Code" erkannt wird. Deshalb ist eine Speicherungsphase notwendig, in der man den Empfänger auf die Erkennung jeder einzelnen Funksteuerung vorbereitet. Die Benutzung als Fernbedienung erfolgt durch Druck auf die Taste (): man wird einen Biepton () bemerken und nach ca. 1 Sekunde die mit ROTEM Licht blinkende LED, was bedeutet, dass gesendet wird; die Sendung erfolgt, solange die Taste gedrückt bleibt. Sie dauert höchstens ca. 12 Sekunden. Das Speicherverfahren hängt vom angewendeten Empfänger ab, daher wird auf seine Anweisungen verwiesen. Für die meisten Automatisierungen gilt das folgende Verfahren: wenn der Speicher keinen Code enthält, kann die erste Funksteuerung auf die in Tabelle A1 angegebene Weise eingegeben werden, wenn dagegen bereits ein oder mehrere Sender gespeichert sind, können weitere wie in Tabelle A2 aktiviert werden.

Tabelle "A1"	Speicherung des ersten Senders	Beispiel
1.	Sobald die Steuerung versorgt wird, hört man 2 lange Bieptöne.	"ON"  5s
2.	Innerhalb von 5 Sekunden auf die Taste  des zu speichernden Senders drücken und diese gedrückt halten (für ca. 3 Sekunden).	 3s
3.	Die Taste  loslassen, wenn man den ersten der 3 Bieptöne hört, welche die Speicherung bestätigen.	 

Anmerkung: Enthält die Steuerung bereits Codes, wird man beim Einschalten 2 kurze Bieptöne (bip) hören und man kann nicht wie oben beschrieben weiter machen; in diesem Fall muss die andere Speicherart (Tabelle „A2“) angewendet werden.

Tabelle "A2"	Speicherung anderer Sender	Beispiel
1.	Auf Taste  des neuen Senders drücken, bis man einen Biepton hört (nach ca. 5 Sekunden).	Neu  5s 
2.	Langsam drei Mal auf Taste  eines bereits aktivierten Senders (alt) drücken.	Alt  X3
3.	Nochmals auf Taste  des neuen Senders drücken.	Neu 
4.	Am Ende werden 3 Bieptöne melden, dass der neue Sender korrekt gespeichert worden ist.	

Anmerkung: Ist der Speicher voll, werden 6 Bieptöne melden, dass der Sender nicht gespeichert werden kann.

4.2) Überprüfung des WINDwächters

- Die Markise auf eine Position zwischen geöffnet und geschlossen bringen.
- Den Windwächter mit einer Geschwindigkeit über dem eingegebenen Ansprechwert drehen lassen, ggf. mit einem Haartrockner (der werkseitig eingestellte Ansprechwert ist 15 Km/h, was ca. 4 Umdrehungen/Sekunde entspricht).
- Nachdem der Ansprechwert WIND mindestens 3 Sekunden lang überschritten ist, muss eine Bewegung in dieselbe Richtung wie mit der Taste  auf den Fernbedienungen erfolgen. Man wird ein Blinken mit ROTEM Licht bemerken, was bedeutet, dass die Übertragung effektiv im Gang ist.

4.3) Überprüfung des SONNENwächters

- Die Stromversorgung zum Motor abschalten und wieder einschalten.
- Die Markise auf eine Position zwischen geöffnet und geschlossen fahren.
- Den Wächter mit einer Lichtquelle (Sonne oder Lampe) mit einer Stärke beleuchten, die höher als der eingestellte Ansprechwert ist (der werkseitig eingestellte Ansprechwert ist 10 Klux, was einem sonnigen Morgen entspricht).
- Nach 2 Minuten muss eine Bewegung in dieselbe Richtung wie mit der Taste  auf den Fernbedienungen erfolgen. Man wird ein Blinken mit GRÜNEM Licht bemerken, was bedeutet, dass die Übertragung effektiv im Gang ist.

5) Programmierungen

Wenn die Ansprechwerte von SONNE oder WIND für die Anwendung nicht geeignet sind, können sie je nach Bedarf geändert werden (Größe der Markise, Stellung, Witterung). Die Ansprechwerte von SONNE und WIND können mit der Taste () gesondert geändert werden, wobei für WIND 5 Werte und für SONNE 6 Werte zur Wahl stehen, wie in den Tabellen B1 und B2 angegeben.

Tabelle "B1" Ansprechwerte WIND
Wert Nr. 1 = 5 Km/h
Wert Nr. 2 = 10 Km/h
Wert Nr. 3 = 15 Km/h
Wert Nr. 4 = 30 Km/h
Wert Nr. 5 = 45 Km/h

Tabelle "B2" Ansprechwerte SONNE
Wert Nr. 1 = 2 KLux
Wert Nr. 2 = 5 KLux
Wert Nr. 3 = 10 KLux
Wert Nr. 4 = 20 KLux
Wert Nr. 5 = 40 KLux
Wert Nr. 6 = aktueller Wert in KLux
Wert Nr. 7 = Ausschluss
Anmerkung: Unter Wert Nr. 6 SONNE ist der in jenem Augenblick gemessene Lichtwert gespeichert.

Zur Änderung der Ansprechwerte, nach den Angaben in Tabellen C1 und C2 vorgehen.





























Tabelle "C1" Änderung des Ansprechwertes der Schutzvorrichtung "WIND" (Abb. 8)	Beispiel
1. Die Taste drücken und loslassen. Beim Loslassen leuchtet die LED auf und bleibt mit ROTEM Licht leuchtend, was bedeutet, dass die Programmierung von WIND im Gang ist.	  
2. Warten, bis man einen Biepton hört.	 
3. Die Taste innerhalb von 4 Sekunden von 1 bis 5 Mal drücken und loslassen, je nach gewähltem Ansprechwert (siehe Tabelle B1).	 X1 = 5 Km/h X2 = 10 Km/h X3 = 15 Km/h X4 = 30 Km/h X5 = 45 Km/h
4. Kurz danach wird man so viele Bieptöne hören, wie der Ansprechwert WIND ist; diese akustische Meldung wird durch ein Blinken mit ROTEM Licht begleitet; die LED bleibt danach mit ROTEM Licht leuchtend.	  X1 = 5 Km/h X2 = 10 Km/h X3 = 15 Km/h X4 = 30 Km/h X5 = 45 Km/h
5. Innerhalb von 4 Sekunden 1 Mal auf die Taste drücken, um zu bestätigen. Dann wird man drei lange Bieptöne hören und die LED erlischt.	   
Anmerkung 1 Sollte man etwas aus irgendeinem Grund bei der Programmierung falsch machen, wird man kurz danach eine Reihe Bieptöne hören und ein Schnellblinker sehen.	      
Anmerkung 2 Am Ende der Programmierung wird eine Leuchtanzeige der eingegebenen Ansprechwerte erfolgen, bzw. die LED wird mit ROTEM Licht sooft blinken, wie der eingegebene Ansprechwert WIND ist, dann mit GRÜNEM Licht für den für SONNE eingegebenen Ansprechwert.	

Tabelle "C2" Änderung oder Ausschluss der Ansprechstufe des "Sonnenwächters" (Abb. 9)	Beispiel
1. Die Taste zwei Mal drücken und loslassen. Beim Loslassen leuchtet die LED auf und bleibt mit GRÜNEM Licht leuchtend, was bedeutet, dass die Programmierung von SONNE im Gang ist.	    
2. Warten, bis man einen Biepton hört.	 
3. Die Taste innerhalb von 4 Sekunden von 1 bis 7 Mal drücken und loslassen, je nach gewähltem Ansprechwert (siehe Tabelle B2).	 X1 = 2 KLux X2 = 5 KLux X3 = 10 KLux X4 = 20 KLux X5 = 40 KLux X6 = Auto X7 = Ausschluss
4. Kurz danach wird man so viele Bieptöne hören, wie der Ansprechwert SONNE ist; diese akustische Meldung wird durch ein Blinken der LED mit GRÜNEM Licht begleitet; die LED bleibt danach mit GRÜNEM Licht leuchtend.	  X1 = 2 KLux X2 = 5 KLux X3 = 10 KLux X4 = 20 KLux X5 = 40 KLux X6 = Auto X7 = Ausschluss
5. Innerhalb von 4 Sekunden 1 Mal auf die Taste drücken, um zu bestätigen. Dann wird man drei lange Bieptöne hören und die LED erlischt.	   
Anmerkung 1 Sollte man etwas aus irgendeinem Grund bei der Programmierung falsch machen, wird man kurz danach eine Reihe Bieptöne hören und ein Schnellblinker sehen.	      
Anmerkung 2 Am Ende der Programmierung wird eine Leuchtanzeige der eingegebenen Ansprechwerte erfolgen, bzw. die LED wird mit ROTEM Licht sooft blinken, wie der eingegebene Ansprechwert WIND ist, dann mit GRÜNEM Licht für den für SONNE eingegebenen Ansprechwert. (7 Mal Blinken bedeutet Ausschluss)	

6) Was tun, wenn...

Obwohl sich der Windwächter mit einer Geschwindigkeit bewegt, die höher als der programmierte Ansprechwert ist, führen die Motoren den Steuerbefehl "Anstieg" (▲) nicht aus.

Die Spannung an den Anschlusskabeln zum Wächter überprüfen; sie muss wie der Nennwert sein. Wenn man einen anderen Wert misst, prüfen, ob der Motor funktioniert und ob der Code des Wächters in jedem Motor und jeder Steuerung, die man mit dem Wächter steuern will, gespeichert ist.

Die Anschlüsse sind richtig und man misst eine ordnungsgemäße Netzspannung an der Verbindung mit dem Wächter, trotzdem erfolgt aber kein Anstieg (▲), wenn sich der Windwächter dreht.

Der Ansprechwert der Schutzvorrichtung WIND muss mindestens 3 Sekunden lang überschritten sein. Den Windwächter mit einer passenden Geschwindigkeit drehen lassen oder ggf. den Ansprechwert WIND im Wächter reduzieren und prüfen, ob die LED mit ROTEM Licht blinkt, was die Sendung des Steuerbefehls bedeutet.

Die Überprüfung des Betriebs von WIND wurde erfolgreich abgeschlossen, die des Betriebs von SONNE dagegen nicht.

Für SONNE wird der Steuerbefehl Abstieg nur 1-mal gegeben, wenn der eingestellte Ansprechwert mindestens 2 Minuten lang überschritten worden ist. Motor und Wächter ausschalten und wieder einschalten, gg. den Ansprechwert SONNE reduzieren und die Prüfung wiederholen. Prüfen, ob die LED mit GRÜNEM Licht blinkt, was die Sendung des Steuerbefehls bedeutet.

Der Wächter funktioniert, hat aber keine Funkreichweite.

Prüfen, ob andere Vorrichtungen vorhanden sind, die auf derselben Frequenz arbeiten und ständig senden, wie Alarmer, Kopfhörer, usw. und eine Reduzierung der Reichweite verursachen könnten.

7) Technische Merkmale

Technische Merkmale

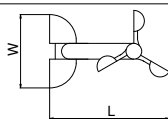
Netzstromversorgung	SKIROSOL SRCK 610	230 Vac 50/60 Hz 1.5W
	SKIROSOL SRCK 610-V1	120 Vac 50/60 Hz 1.5W
Übertragungsfrequenz	433.92 MHz	LPD mit eingebauter Antenne
Ausgestrahlte Leistung	ca. 1 mW (e.r.p.)	Entspricht unter optimalen Bedingungen einer Reichweite von ca. 100-200 m
Schutzart IP	IP 44	
Betriebstemperatur	-20 °C ÷ +55 °C	
Gehäuse	Abmessungen	
	Gewicht	P = 250 g

Merkmale der Wächter

Windwächter	Range	0-127 Km/h
	Auflösung	1 Km/h
	Umrechnungskonstante	0.26 $\frac{\text{Giri}}{\text{s}}$ Km / h
	Präzision	± 2 % F.S.
	Programmierbare Ansprechwerte	1 = 5 Km/h 2 = 10 Km/h 3 = 15 Km/h 4 = 30 Km/h 5 = 45 Km/h
Luxmeter	Range	0 ÷ 64 KLux
	Auflösung (KLux)	0 - 10 KLux: 0.25 KLux 10 - 40 KLux: 0.5 KLux 40 - 64 KLux: 1 KLux
	Präzision	± 10% F.S.
	Programmierbare Ansprechwerte	1 = 2 KLux 2 = 5 KLux 3 = 10 KLux 4 = 20 KLux 5 = 40 KLux 6 = AUTO 7 = AUSSCHLUSS

Änderungen vorbehalten.



Avertissements:

Pour l'installation, la maintenance et la réparation du produit, s'adresser uniquement à du personnel technique compétent qui doit exécuter les interventions dans le plein respect des normes légales en vigueur.

⚠ Lire attentivement les instructions et vérifier quels moteurs ou logiques de commande peuvent être utilisés avec le capteur climatique SKIROSOL SRCK 610. Toute autre utilisation est impropre et interdite.

1) Description du produit

Le capteur climatique SKIROSOL SRCK 610 mesure la vitesse du VENT en Km/h et l'intensité de la lumière solaire en KLux. Il peut être utilisé pour commander des moteurs ou des logiques adaptées et permet d'automatiser, à travers une commande par radio, en fonction des conditions atmosphériques détectées, le mouvement de stores, volets roulants et similaires. Par exemple, dans le cas d'un store, le dépassement du niveau programmé de SOLEIL en commande l'ouverture, le dépassement du niveau de VENT en commande la fermeture. Les commandes sont envoyées par radio, donc les seules connexions à effectuer sont celles qui sont relatives à la ligne électrique (voir chapitre "Installation").

SKIROSOL SRCK 610 est muni d'une touche () de programmation ou transmission (Fig.1 détail B), et d'un voyant (LED ) multicolore (Fig.1 détail C); il possède en outre une indication acoustique (Bip ).

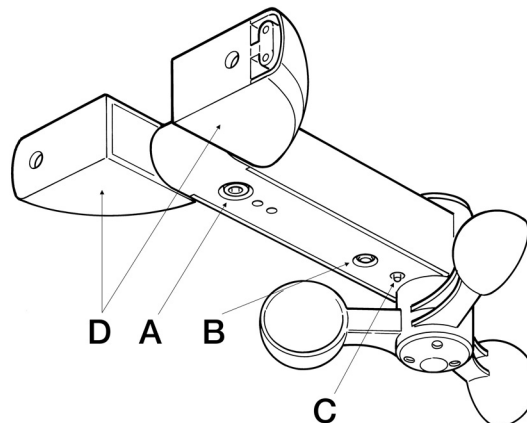

1.1) Règles de commande

SKIROSOL SRCK 610 mesure la vitesse du VENT et l'intensité du SOLEIL, quand la valeur dépasse le niveau programmé, une commande est envoyée aux moteurs ou aux logiques de commande de la manière suivante:

Vent: quand le niveau de "VENT" est dépassé pendant au moins 3 secondes, le capteur envoie une commande de "montée" équivalant à la touche ▲ des télécommandes. Quand le niveau est dépassé, la LED devient rouge et durant l'envoi de la commande on a un clignotement de la LED avec lumière ROUGE.

Soleil: quand le niveau de "SOLEIL" est dépassé pendant au moins 2 minutes, le capteur envoie une commande de "descente" équivalant à la touche ▼ des télécommandes. Quand le niveau est dépassé, la LED devient VERTE et durant l'envoi de la commande on a un clignotement de la LED avec lumière VERTE.

Priorités: si les deux niveaux sont dépassés, la priorité est donnée à la protection "VENT" par rapport à la protection "SOLEIL", suivant un principe de sécurité. Seulement après la cessation du dépassement du niveau de "VENT" depuis au moins 2 minutes, la protection "SOLEIL" peut intervenir avec sa propre règle.

Chaque commande est répétée périodiquement jusqu'à la cessation du dépassement du niveau.

SKIROSOL SRCK 610 transmet en outre les données mesurées de vitesse du VENT en Km/h, intensité lumineuse du SOLEIL en KLux, présence de la PLUIE*, TEMPÉRATURE*, HUMIDITÉ*.

(* = seulement pour les versions équipées du capteur correspondant)

2) Installation

Avant de procéder à l'installation, il est conseillé de vérifier la portée radio car la présence de murs épais et/ou d'autres dispositifs opérant à la même fréquence peuvent réduire de beaucoup la portée.

Pour la vérification, effectuer provisoirement un essai de fonctionnement (voir le chapitre "Essai de fonctionnement"), en se plaçant d'abord près de l'automatisme puis près du point d'installation définitif. Même si la portée dans des conditions favorables en champ libre peut être de 100-200 m, considérant la fonction de protection, il est conseillé de ne pas dépasser 20-30 m. Il est conseillé, en outre, de vérifier qu'il n'y a pas d'autres dispositifs opérant à la même fréquence et avec des transmissions continues tels que des alarmes, des écouteurs radio, etc. qui pourraient en réduire ultérieurement la portée.

Pour le fonctionnement correct, nous rappelons que le capteur climatique doit être positionné à proximité du store ou volet roulant à protéger et

dans une zone exposée à l'action du vent et du soleil.

Pour procéder à l'installation, se référer aux Fig.2, Fig.3, Fig.4 et Fig.7, en se rappelant de ne pas serrer trop fort le vis de fixation (Fig.1 détail A).

⚠ SKIROSOL SRCK 610 étant alimenté à la tension de secteur, il est conseillé de le placer dans un endroit qui ne soit pas facilement accessible.

3) Branchements électriques

Le produit doit être connecté à une alimentation 230 Vca (version SKIROSOL SRCK 610), ou de 120 Vca (version SKIROSOL SRCK 610-V1), sans mise à la terre, comme l'indiquent les Fig.5, Fig.6 et Fig.7.

Après avoir effectué le câblage, fermer soigneusement les couvercles de l'étrier de fixation (Fig.1 détail D).

4) Essai de fonctionnement

Le fait d'alimenter le capteur aura les effets suivants:







- indication acoustique d'allumage (4 Bips )
- quelques clignotements avec lumière ROUGE (préprogrammé = 3 ) , équivalant au niveau de VENT programmé, puis quelques clignotements avec lumière VERTE (préprogrammé = 3 ) , équivalant au niveau de SOLEIL programmé.

Tableau "A"	Alumage	Exemple
1.	Dès que la logique de commande aura été alimentée, on entendra 4 longs bips.	
2.	Indication du niveau VENT à travers quelques clignotements avec lumière ROUGE.	
3.	Indication du niveau SOLEIL à travers quelques clignotements avec lumière VERTE.	

Pour les correspondances entre le nombre de clignotements et la valeur des niveaux, voir les tableaux B1 et B2.

Dans la description qui suit, nous ferons référence à l'utilisation d'un moteur pour stores, des procédures analogues peuvent être utilisées également dans d'autres cas. Pour vérifier l'installation correcte du capteur, suivre les phases ci-après.

4.1) Mémorisation du code

















Mémorisation du code. Pour que les commandes envoyées par le capteur agissent sur les moteurs et/ou les logiques de commande, il faut mémoriser le code comme dans une télécommande. En effet, chaque télécommande est reconnue par le récepteur à travers un "code" différent de tous les autres. Une phase de "mémorisation" est donc nécessaire pour préparer le récepteur à reconnaître chaque émetteur. L'utilisation comme télécommande s'effectue en pressant la touche () : on entendra un bip puis () , au bout d'environ 1 seconde, on verra clignoter la LED avec lumière ROUGE, qui indique ainsi que la transmission est en train de se faire; elle s'effectue tant que la touche est pressée. La transmission dure au maximum environ 12 s. La procédure de mémorisation dépend du type de récepteur. Il faut donc se référer aux instructions relatives à cette dernière. La plupart des automatisés suit la procédure ci-après: quand la mémoire ne contient aucun code, on peut procéder à l'enregistrement du premier émetteur avec la modalité du Tableau A1, autrement, si un ou plusieurs émetteurs ont déjà été mémorisés, on peut en enregistrer d'autres avec la modalité du Tableau A2.

Tableau "A1"	Mémorisation du premier émetteur	Exemple
1.	Dès que la logique de commande aura été alimentée, on entendra 2 longs bips.	"ON"  5s
2.	Dans les 5 secondes, presser et maintenir enfoncée la touche  de l'émetteur à mémoriser (pendant environ 3 secondes).	 3s
3.	Relâcher la touche  quand on entendra le premier des 3 bips qui confirment la mémorisation.	 

Note: Si la logique contient déjà des codes, à l'allumage on entendra 2 brefs bips et il ne sera pas possible de procéder suivant le tableau A1 mais il faudra utiliser l'autre mode de mémorisation (Tableau "A2").

Tableau "A2"	Mémorisation d'autres émetteurs	Exemple
1.	Maintenir enfoncée la touche  du nouvel émetteur jusqu'à ce que l'on entende un bip (au bout d'environ 5 secondes).	Nouveau  5s 
2.	Presser lentement 3 fois la touche  d'un émetteur déjà enregistré (ancien).	Ancien  X3
3.	Presser encore la touche  du nouvel émetteur.	Nouveau 
4.	À la fin, 3 bips signaleront que le nouvel émetteur a été correctement mémorisé.	

Note: Si la mémoire est pleine, 6 Bips indiqueront que l'émetteur ne peut pas être mémorisé.

4.2) Vérification du capteur VENT

- Positionner le store à un point intermédiaire entre l'ouverture et la fermeture.
- Faire tourner l'anémomètre (en utilisant éventuellement un sèche-cheveux) à une vitesse supérieure au niveau programmé (en usine, le niveau programmé est de 15 Km/h qui correspond à environ 4 tours/seconde).
- Quand le niveau de la protection VENT a été dépassé depuis au moins 3 secondes, une manœuvre doit démarrer dans la direction correspondant à la touche  des télécommandes. On remarquera un clignotement avec lumière ROUGE, indiquant la transmission effective de la commande.

4.3) Vérification du capteur SOLEIL

- Couper et rétablir l'alimentation au moteur et au capteur.
- Positionner le store à un point intermédiaire entre l'ouverture et la fermeture.
- Éclairer le capteur avec une source lumineuse (soleil ou lampe) avec une intensité supérieure au niveau programmé (en usine le niveau programmé est de 10 KLux, correspondant au SOLEIL d'un matin sans nuages).
- Au bout de 2 minutes, une manœuvre correspondant à la touche  des télécommandes doit démarrer. On remarquera un clignotement avec lumière VERTE, indiquant la transmission effective de la commande.

5) Programmations

Si les niveaux d'intervention des protections SOLEIL ou VENT ne sont pas adaptés à l'application, il est possible de les modifier suivant les exigences personnelles (dimensions du store, position, exigence atmosphérique). Les niveaux d'intervention des protections SOLEIL et VENT peuvent être modifiés un par un à l'aide de la touche (), en choisissant entre 5 valeurs de VENT et 6 de SOLEIL comme l'indiquent les tableaux B1 et B2.

Tableau "B1" Niveaux VENT
Niveau N° 1 = 5 Km/h
Niveau N° 2 = 10 Km/h
Niveau N° 3 = 15 Km/h
Niveau N° 4 = 30 Km/h
Niveau N° 5 = 45 Km/h

Tableau "B2" Niveaux SOLEIL
Niveau N° 1 = 2 KLux
Niveau N° 2 = 5 KLux
Niveau N° 3 = 10 KLux
Niveau N° 4 = 20 KLux
Niveau N° 5 = 40 KLux
Niveau N° 6 = Valeur actuelle KLux
Niveau N° 7 = Exclusion

Note: Dans la programmation du niveau 6 du SOLEIL, la valeur de luminosité mesurée à ce moment-là est mémorisée

Pour changer les niveaux d'intervention, suivre les indications figurant dans les Tableaux C1 et C2.







































Tableau "C1" Changer le niveau d'intervention de la protection "VENT" (Fig.8)	Exemple
1. Presser et relâcher la touche. Quand on relâche la touche, la LED s'allume et reste allumée avec lumière ROUGE, indiquant que l'on est dans la phase de programmation VENT.	  
2. Attendre jusqu'à ce que l'on entende un Bip.	 
3. Dans les 4 secondes, presser et relâcher la touche de 1 à 5 fois, suivant le niveau choisi (voir Tableau B1).	 X1 = 5 Km/h X2 = 10 Km/h X3 = 15 Km/h X4 = 30 Km/h X5 = 45 Km/h
4. Au bout de quelques instants, on entendra un nombre de Bips accompagnés de clignotements avec lumière ROUGE, égal au niveau du VENT programmé ; ensuite la LED reste allumée avec lumière ROUGE.	X1 = 5 Km/h X2 = 10 Km/h   X3 = 15 Km/h X4 = 30 Km/h X5 = 45 Km/h
5. Dans les 4 secondes, presser la touche 1 fois. En confirmation, on entendra 3 longs Bips et la LED s'éteindra.	   
Note 1 Si pour une raison quelconque une erreur se vérifie dans la programmation, au bout de quelques instants on entendra une série de Bips et clignotements brefs.	     
Note 2 À la fin de la programmation, on aura une indication lumineuse des niveaux programmés, à travers un nombre de clignotements avec lumière ROUGE correspondant au niveau VENT programmé, puis un nombre de clignotements avec lumière VERTE, correspondant au niveau SOLEIL programmé.	

Tableau "C2" Changer ou exclure le niveau d'intervention du "soleil" (Fig.9)	Exemple
1. Presser et relâcher la touche deux fois. Quand on relâche la touche, la LED s'allume et reste allumée avec lumière VERTE, indiquant que l'on est dans la phase de programmation SOLEIL.	    
2. Attendre jusqu'à ce que l'on entende un Bip.	 
3. Dans les 4 secondes, presser et relâcher la touche de 1 à 7 fois, suivant le niveau choisi (voir Tableau B2).	 X1 = 2 KLux X2 = 5 KLux X3 = 10 KLux X4 = 20 KLux X5 = 40 KLux X6 = Auto X7 = Exclusion
4. Au bout de quelques instants, on entendra un nombre de Bips accompagnés de clignotements avec lumière VERTE, égal au niveau de SOLEIL programmé ; ensuite la LED reste allumée avec lumière VERTE.	X1 = 2 KLux X2 = 5 KLux X3 = 10 KLux   X4 = 20 KLux X5 = 40 KLux X6 = Auto X7 = Exclusion
5. Dans les 4 secondes, presser la touche 1 fois. En confirmation, on entendra 3 longs Bips et la LED s'éteindra.	   
Note 1 Si pour une raison quelconque une erreur se vérifie dans la programmation, au bout de quelques instants on entendra une série de Bips et clignotements brefs.	     
Note 2 À la fin de la programmation, on aura une indication lumineuse des niveaux programmés, à travers un nombre de clignotements avec lumière ROUGE correspondant au niveau VENT programmé, puis un nombre de clignotements avec lumière VERTE, correspondant au niveau SOLEIL programmé. (7 clignotements indiquent l'exclusion)	

6) Que faire si...

Même quand on fait tourner l'anémomètre à une vitesse supérieure au niveau programmé, les moteurs connectés n'exécutent pas la commande de "montée" (▲).

Vérifier la tension présente sur les câbles de connexion du capteur qui doit être égale à la valeur nominale. Si une valeur différente est mesurée, contrôler les connexions, vérifier si le moteur fonctionne; vérifier d'avoir mémorisé le code du capteur dans chaque moteur ou logique de commande que l'on désire commander avec ce dispositif.

Les connexions sont correctes et la tension mesurée sur la connexion du capteur correspond à la tension de secteur mais quand on fait tourner l'anémomètre, la manœuvre de montée (▲) n'est pas exécutée.

Le niveau d'intervention de la protection VENT doit être dépassée pendant au moins 3 secondes, faire tourner l'anémomètre à une vitesse appropriée, essayer éventuellement d'abaisser le niveau d'intervention de la protection VENT dans le capteur, vérifier le clignotement de la LED avec lumière ROUGE indiquant la transmission de la commande.

La vérification du fonctionnement de la protection VENT s'est conclue positivement mais pas celle de la protection SOLEIL.

La manœuvre de descente en cas de SOLEIL est commandée seulement une fois quand le seuil programmé est dépassé pendant au moins 2 minutes. Essayer d'éteindre et de rallumer le moteur et le capteur et répéter l'essai ; abaisser éventuellement le niveau d'intervention de la protection SOLEIL. Vérifier le clignotement de la LED avec lumière VERTE indiquant la transmission de la commande.

Le capteur fonctionne mais n'a pas de portée radio.

Vérifier qu'il n'y a pas d'autres dispositifs opérant à la même fréquence et avec des transmissions continues tels que des alarmes, des écouteurs radio, etc. qui pourraient réduire la portée.

7) Caractéristiques techniques

Caractéristiques générales

Alimentation de secteur	SKIROSOL SRCK 610	230 Vac 50/60 Hz 1.5W
	SKIROSOL SRCK 610-V1	120 Vac 50/60 Hz 1.5W
Fréquence de transmission	433.92 MHz	LPD avec antenne incorporée
Puissance irradiée	environ 1 mW (ERP)	Dans des conditions optimales, elle correspond à une portée d'environ 100-200m
Protection IP	IP 44	
Température d'utilisation	-20 °C ÷ +55 °C	
Boîtier	Dimensions	W = 120 mm L = 215 mm H = 85 mm
	Poids	P = 250 g

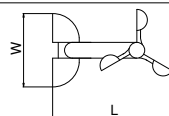

Caractéristiques capteurs

Anémomètre	Plage	0-127 Km/h
	Résolution	1 Km/h
	Constante de conversion	0,26 $\frac{\text{Tuors}}{\text{s}}$ Km / h
	Précision	± 2 % F.S.
	Niveaux programmables	Niv. 1 = 5 Km/h Niv. 2 = 10 Km/h Niv. 3 = 15 Km/h Niv. 4 = 30 Km/h Niv. 5 = 45 Km/h
Luxmètre	Plage	0 ÷ 64 KLux
	Résolution (KLux)	0 - 10 KLux: 0.25 KLux 10 - 40 KLux: 0.5 KLux 40 - 64 KLux: 1 KLux
	Précision	± 10% F.S.
	Niveaux programmables	Niv. 1 = 2 KLux Niv. 2 = 5 KLux Niv. 3 = 10 KLux Niv. 4 = 20 KLux Niv. 5 = 40 KLux Niv. 6 = AUTO Niv. 7 = EXCLUSION

Sous réserve de changements.

Avvertenze:



Per l'installazione, la manutenzione e la riparazione del prodotto rivolgersi solo a personale tecnico competente, il quale deve eseguire le stesse nel pieno rispetto delle norme di legge vigenti.

⚠ Leggere attentamente le istruzioni e verificare quali motori o centrali possono essere utilizzati con il sensore climatico SKIROSOL SRCK 610. Ogni altro uso è improprio e vietato.

1) Descrizione del prodotto

Il sensore climatico SKIROSOL SRCK 610, misura la velocità del VENTO in Km/h e l'intensità della luce solare in KLux.

Può essere utilizzato per comandare motori o centrali predisposte consentendo di automatizzare, tramite un comando via radio, in funzione delle condizioni atmosferiche rilevate, il movimento di tende, avvolgibili e similari. Ad esempio nel caso di una tenda, il superamento del livello di SOLE ne comanda l'apertura, il superamento del livello di VENTO ne comanda la chiusura. I comandi vengono inviati via radio, quindi gli unici collegamenti da effettuare, sono quelli relativi alla linea elettrica (si veda il Capitolo "Installazione").

SKIROSOL SRCK 610 è dotato di tastino () di programmazione o trasmissione (Fig.1 particolare B), e di un indicatore luminoso (LED ) multi-colore (Fig.1 particolare C); vi è inoltre una indicazione acustica (Beep ).

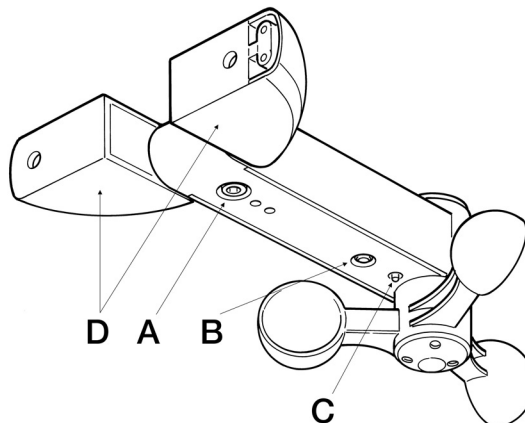

1

1.1) Regole di comando

SKIROSOL SRCK 610 misura la velocità del VENTO e l'intensità del SOLE, quando il valore supera il livello programmato, viene inviato un comando ai motori o centrali come di seguito specificato:

Vento: quando il livello di "VENTO" viene superato per almeno 3 secondi, invia un comando di "salita" equivalente al tasto  dei telecomandi.

Al superamento della soglia il LED Diventa ROSSO e durante l'invio del comando, si ha un lampeggio del LED con luce ROSSA.

Sole: quando il livello di "SOLE" viene superato per almeno 2 minuti, invia un comando di "discesa" equivalente al tasto  dei telecomandi. Al superamento della soglia il LED Diventa VERDE e durante l'invio del comando, si ha un lampeggio del LED con luce VERDE.

Precedenze: se entrambi i livelli sono superati, la precedenza è data al "VENTO" rispetto al "SOLE", secondo un principio di sicurezza.

Solo dopo la cessazione di "VENTO" da almeno 2 minuti può intervenire il "SOLE" con la propria regola.

Ogni comando è ripetuto periodicamente fino alla cessazione del superamento del livello.

SKIROSOL SRCK 610 trasmette inoltre, i dati misurati di velocità del VENTO in Km/h, intensità luminosa del SOLE in KLux, presenza della PIOGGIA*, TEMPERATURA*, UMIDITA**.

(* = solo per versioni con relativo sensore)

2) Installazione

Prima di effettuare l'installazione è consigliata una verifica di portata radio; visto che la presenza di grossi muri e/o altri dispositivi operanti alla stessa frequenza possono ridurre di molto la portata. Per verificare ciò, effettuare provvisoriamente un collaudo (si veda il Capitolo "Collaudo"), posizionandosi, prima nei pressi dell'automazione e successivamente, vicino al punto di installazione definitivo. Benchè la portata in condizioni favorevoli in campo libero possa essere di 100-200 m, considerando la funzione di protezione, si consiglia di non superare i 20-30 m. Si consiglia inoltre, di verificare che non vi siano altri dispositivi operanti alla stessa frequenza e con trasmissioni continue come allarmi, radiocuffie, ecc... che potrebbero ridurre ulteriormente la portata.

Per il corretto funzionamento, si ricorda che il sensore climatico deve essere posizionato in prossimità dell'avvolgibile da proteggere ed in una zona esposta all'azione del vento e del sole.

Per procedere all'installazione fare riferimento alle Fig.2, Fig.3, Fig.4 e Fig. 7, ricordandosi di non stringere con forza la vite di fissaggio (Fig.1 particolare A).

⚠ Essendo SKIROSOL SRCK 610 alimentato alla tensione di rete, si consiglia porlo in un punto non facilmente accessibile.

3) Collegamenti elettrici

Il prodotto deve essere collegato ad un'alimentazione 230Vac (versione SKIROSOL SRCK 610), o di 120Vac (versione SKIROSOL SRCK 610-V1), senza connessione a terra, come indicato nelle Fig.5, Fig.6 e Fig.7.

Eseguito il cablaggio, chiudere accuratamente i coperchi della staffa di fissaggio (Fig.1 particolare D).

4) Collaudo

Dando tensione al sensore, avverranno le seguenti azioni:





- indicazione acustica di accensione (4 Beep )
- alcuni lampeggi con luce ROSSA (preprogrammato = 3 ) , pari al livello di VENTO impostato, poi alcuni lampeggi con luce VERDE (preprogrammato = 3 ) , pari al livello di SOLE impostato.

Tabella "A"	Accensione	Esempio
1.	Appena data alimentazione alla centrale, si sentiranno 4 Beep	
2.	Indicazione del livello Vento, attraverso alcuni lampeggi con luce ROSSA	
3.	Indicazione del livello Sole, attraverso alcuni lampeggi con luce VERDE	

Per le corrispondenze tra numero di lampeggi e valore dei livelli si vedano le Tabelle B1 e B2.

Nella descrizione seguente si farà riferimento all'utilizzo di un motore per tende, procedimenti analoghi si potranno utilizzare anche per gli altri casi. Per verificare la corretta installazione del sensore seguire i seguenti passi.

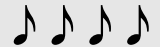
4.1) Memorizzazione del codice

















Affinché i comandi inviati dal sensore abbiano effetto sui motori e/o sulle centrali, è necessario memorizzare il codice come in un telecomando. Infatti ogni telecomando viene riconosciuto dalla ricevente, attraverso un "codice" diverso da ogni altro. E' necessaria quindi una fase di "memorizzazione" attraverso la quale si predispongono la ricevente a riconoscere ogni singolo radiocomando. L'utilizzazione come telecomando avviene premendo il tastino (): si avvertirà un beep () e, dopo circa 1 secondo si noterà il LED con luce ROSSA lampeggiare, indicando che trasmette; la trasmissione avviene finché il tasto è premuto. La trasmissione dura al massimo circa 12s. La procedura di memorizzazione dipende dalla ricevente impiegata, pertanto si vedano le istruzioni relative alla stessa. La maggior parte delle automazioni, segue la seguente procedura: quando la memoria non contiene nessun codice si può procedere all'inserimento del primo radiocomando con la modalità di Tabella A1, altrimenti se uno o più trasmettitori sono già stati memorizzati, è possibile abilitarne altri con la modalità di Tabella A2.

Tabella "A1"	Memorizzazione del primo trasmettitore	Esempio
1.	Appena data alimentazione alla centrale, si sentiranno 2 beep lunghi.	"ON"  5s
2.	Entro 5 secondi premere e tener premuto il tasto  del trasmettitore da memorizzare (per circa 3 secondi).	 3s
3.	Rilasciare il tasto  quando si sentirà il primo dei 3 beep che confermano la memorizzazione.	 

Nota: Se la centrale contiene già dei codici, all'accensione si udiranno 2 beep brevi e non si potrà procedere come descritto sopra ma occorre usare l'altra modalità di memorizzazione (Tabella "A2").

Tabella "A2"	Memorizzazione di altri trasmettitori	Esempio
1.	Tenete premuto il tasto  del nuovo trasmettitore fino a sentire 1 beep (dopo circa 5 secondi).	Nuovo  5s 
2.	Lentamente premere per 3 volte il tasto  di un trasmettente già abilitato (vecchio).	Vecchio  X3
3.	Premere ancora il tasto  del nuovo trasmettitore.	Nuovo 
4.	Alla fine 3 beep segneranno che il nuovo trasmettitore è stato memorizzato correttamente.	

Nota: Se la memoria è piena, 6 Beep indicheranno il trasmettitore non può essere memorizzato.

4.2) Verifica del sensore VENTO

- Posizionare la tenda in un punto intermedio tra l'apertura e la chiusura.
- Far girare l'anemometro (avvalendosi eventualmente di un asciugacapelli) ad una velocità superiore al livello impostato (dalla fabbrica il livello impostato è di 15 Km/h che corrisponde a circa 4 giri/secondo).
- Dopo che il livello del VENTO è stato superato da almeno 3 secondi deve partire una manovra nella direzione equivalente al tasto  dei telecomandi. Si noterà un lampeggio con luce ROSSA, indicante l'effettiva trasmissione del comando.

4.3) Verifica del sensore SOLE

- Togliere e ridare alimentazione al motore ed al sensore.
- Posizionare la tenda in un punto intermedio tra la chiusura e l'apertura.
- Illuminare il sensore con una sorgente luminosa (sole o lampada) con una intensità superiore al livello impostato (dalla fabbrica il livello impostato è di 10 KLux, corrispondente al SOLE di una mattina serena).
- Dopo 2 minuti deve partire una manovra equivalente al tasto  dei telecomandi. Si noterà un lampeggio con luce VERDE, indicante la effettiva trasmissione del comando.

5) Programmazione

Se i livelli di intervento di SOLE o VENTO non sono adeguati all'applicazione, è possibile modificarli secondo le proprie esigenze (dimensioni della tenda, posizione, esigenza atmosferica). I livelli di intervento del SOLE e del VENTO, possono essere modificati singolarmente tramite il tastino (🔘), scegliendo tra 5 valori di VENTO e 6 di SOLE come riportato nelle Tabelle B1 e B2.

Tabella "B1" Livello VENTO
Livello N° 1 = 5 Km/h
Livello N° 2 = 10 Km/h
Livello N° 3 = 15 Km/h
Livello N° 4 = 30 Km/h
Livello N° 5 = 45 Km/h

Tabella "B2" Livello SOLE
Livello N° 1 = 2 KLux
Livello N° 2 = 5 KLux
Livello N° 3 = 10 KLux
Livello N° 4 = 20 KLux
Livello N° 5 = 40 KLux
Livello N° 6 = Valore Attuale KLux
Livello N° 7 = Esclusione

Nota: Nella programmazione del livello 6 del SOLE, è memorizzato il valore misurato di luminosità in quell'istante

Per cambiare i livelli di intervento, seguire le indicazioni riportate nelle Tabelle C1 e C2.







































Tabella "C1" Cambiare livello di intervento della protezione "VENTO" (Fig. 8)	Esempio
1. Premere e rilasciare il tastino. Al rilascio il LED si accende e rimane acceso con luce ROSSA, indicando la fase di programmazione VENTO.	  
2. Attendere finché si udirà un Beep.	 
3. Entro 4 secondi premere e rilasciare il tastino da 1 a 5 volte, in base al livello scelto (si veda Tabella B1).	 X1 = 5 Km/h X2 = 10 Km/h X3 = 15 Km/h X4 = 30 Km/h X5 = 45 Km/h
4. Dopo qualche istante si udirà un numero di Beep accompagnati da lampeggi con luce ROSSA, pari al livello del VENTO impostato; in seguito il LED rimane acceso con luce ROSSA.	X1 = 5 Km/h X2 = 10 Km/h   X3 = 15 Km/h X4 = 30 Km/h X5 = 45 Km/h
5. Entro 4 secondi premere il tastino 1 volta per conferma, si udiranno tre Beep lunghi ed il LED si spegne.	   
Nota 1 Se per qualsiasi ragione si dovesse sbagliare qualcosa nella programmazione, dopo alcuni istanti si udiranno una serie di Beep e lampeggi Brevi.	     
Nota 2 Al termine della programmazione, si avrà un'indicazione luminosa dei livelli impostati, mediante lampeggi con luce ROSSA pari al livello VENTO impostato, poi lampeggi con luce VERDE, pari al livello SOLE impostato.	

Tabella "C2" Cambiare od escludere il livello d'intervento del "SOLE" (Fig. 9)	Esempio
1. Premere e rilasciare il tastino due volte. Al rilascio il LED si accende e rimane acceso con luce VERDE, indicando che siamo in programmazione SOLE.	    
2. Attendere finché si udirà un Beep.	 
3. Entro 4 secondi premere e rilasciare il tastino da 1 a 7 volte, in base al livello scelto (si veda Tabella B2).	 X1 = 2 KLux X2 = 5 KLux X3 = 10 KLux X4 = 20 KLux X5 = 40 KLux X6 = Auto X7 = Esclusione
4. Dopo qualche istante si udirà un numero di Beep accompagnati da lampeggi con luce VERDE, pari al livello di SOLE impostato, in seguito il LED rimane acceso con luce VERDE.	X1 = 2 KLux X2 = 5 KLux   X3 = 10 KLux X4 = 20 KLux X5 = 40 KLux X6 = Auto X7 = Esclusione
5. Entro 4 secondi premere il tastino 1 volta per conferma, si udiranno tre Beep lunghi ed il LED si spegne.	   
Nota 1 Se per qualsiasi ragione si dovesse sbagliare qualcosa nella programmazione, dopo alcuni istanti si udiranno una serie di Beep e lampeggi Brevi.	     
Nota 2 Al termine della programmazione, si avrà una indicazione luminosa dei livelli impostati, mediante lampeggi con luce ROSSA pari al livello VENTO impostato, poi lampeggi con luce VERDE, pari al livello SOLE impostato (7 lampeggi indicano esclusione).	

6) Cosa fare se...

Anche facendo ruotare l'anemometro ad una velocità superiore al livello programmato i motori non eseguono il comando di "salita" (▲).

Verificare la tensione ai morsetti di collegamento al sensore, deve essere pari al valore nominale. Se si misura un valore diverso controllare le connessioni, verificare se il motore è funzionante; verificare di aver memorizzato il codice del sensore in ogni motore o centrale che si vuole comandare con esso.

I collegamenti sono corretti e si misura una tensione di rete regolare sul collegamento del sensore, ma facendo ruotare l'anemometro non viene eseguita la manovra di salita (▲).

Il livello di intervento per la protezione VENTO deve essere superato per almeno 3 secondi, far ruotare l'anemometro ad una velocità opportuna, eventualmente provare ad abbassare il livello di intervento del VENTO nel sensore, verificare il lampeggio del LED con luce ROSSA indicante la trasmissione del comando.

La verifica del funzionamento VENTO si è conclusa positivamente, ma la verifica dell'intervento SOLE no.

La manovra di discesa per SOLE viene comandata solamente 1 volta quando il livello impostato viene superato per almeno 2 minuti. Provare a spegnere e riaccendere il motore ed il sensore ripetere la prova eventualmente abbassare il livello di intervento del SOLE nei motori o centrali. Verificare il lampeggio del LED con luce VERDE indicante la trasmissione del comando.

Il sensore funziona, ma non ha portata radio.

Verificare che non vi siano altri dispositivi operanti alla stessa frequenza e con trasmissioni continue come allarmi, radiocuffie, ecc... che potrebbero ridurre la portata.

7) Caratteristiche tecniche

Caratteristiche generali

Alimentazione da rete	SKIROSOL SRCK 610	230 Vac 50/60 Hz 1.5W
	SKIROSOL SRCK 610-V1	120 Vac 50/60 Hz 1.5W
Frequenza di Trasmissione	433.92 MHz	LPD con antenna integrata
Potenza Irradiata	Circa 1 mW (e.r.p.)	In condizioni ottimali corrisponde ad una portata di circa 100-200m
Protezione IP	IP 44	
Temperatura di utilizzo	-20 °C ÷ +55 °C	
Contenitore	Dimensioni	 W = 120 mm L = 215 mm H = 85 mm
	Peso	P = 250 g

Caratteristiche sensori

Anemometro	Range	0-127 Km/h
	Risoluzione	1 Km/h
	Costante di conversione	0,26 $\frac{\text{Giri / s}}{\text{Km / h}}$
	Accuratezza	± 2 % F.S.
	Livelli programmabili	Liv 1 = 5 Km/h Liv 2 = 10 Km/h Liv 3 = 15 Km/h Liv 4 = 30 Km/h Liv 5 = 45 Km/h
Luxmetro	Range	0 ÷ 64 KLux
	Risoluzione (KLux)	0 - 10 KLux: 0.25 KLux 10 - 40 KLux: 0.5 KLux 40 - 64 KLux: 1 KLux
	Accuratezza	± 10% F.S.
	Livelli programmabili	Liv 1 = 2 KLux Liv 2 = 5 KLux Liv 3 = 10 KLux Liv 4 = 20 KLux Liv 5 = 40 KLux Liv 6 = AUTO Liv 7 = ESCLUSIONE

Con riserva di apportare modifiche.

Warnings:

For product installation, maintenance and repairs contact only qualified technical personnel, who must comply with the legislation in force.

⚠ Read the instructions carefully and verify which motors or control units are suitable for use with the SKIROSOL SRCK 610 weather sensor. Any other application is improper and prohibited.

1) Product description

The SKIROSOL SRCK 610 weather sensor measures WIND speed in Km/h, and the brightness of sunlight in KLux.

It can be used to command programmed motors or control units, enabling the automation of awnings, rolling shutters and similar fixtures via a radio control, based on the detected weather conditions.

For example, awnings will open automatically when the programmed SUNLIGHT level is exceeded, and will close when the WIND level is exceeded.

The commands are sent by radio, therefore the only connections required are the electric line ones (see the "Installation" chapter).

SKIROSOL SRCK 610 is equipped with a programming/transmission button (🔘) (Fig. 1, detail B) and a multicoloured indicator light (LED ⊗) (Fig. 1, detail C). It also features an audible signal (Beep 🗣).

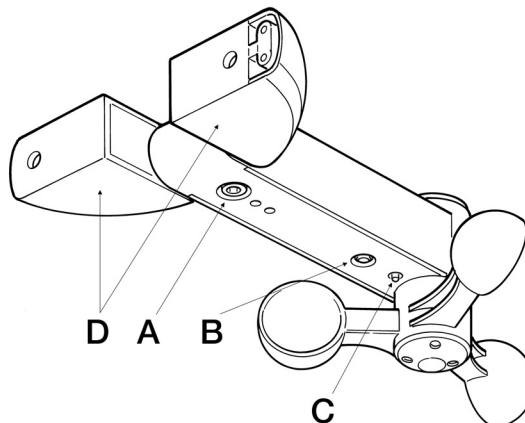

1.1) Command rules

SKIROSOL SRCK 610 measures WIND speed and brightness of SUNLIGHT. When the detected value exceeds the programmed level, a command is sent to the motors or control units as described below:

Wind: when the WIND level is exceeded for a period of at least 3 seconds, an "up" command (corresponding to button ▲ on the remote controls) is sent. When the threshold value is exceeded, the LED becomes red and while the command is being transmitted, the RED LED flashes.

Sun: when the SUN level is exceeded for a period of at least 2 minutes, a "down" command (corresponding to button ▼ on the remote controls) is sent. When the threshold value is exceeded, the LED becomes GREEN and while the command is being transmitted, the GREEN LED flashes.

Precedence: if both levels are exceeded, precedence is given to WIND before SUN for safety reasons. Only after the WIND level has dropped below the set value for at least 2 minutes, the SUN command is enabled.

Each command is repeated at periodic intervals until the SUN/WIND level drops below the set limits.

SKIROSOL SRCK 610 transmits the measured WIND speed in Km/h, brightness of SUNLIGHT in Klux, plus RAIN*, TEMPERATURE* and HUMIDITY* readings.

(* = only for versions with special sensor)

2) Installation

Before you install the unit, test the radio range, as the presence of thick walls and/or other devices operating at the same frequency can greatly reduce the range. To check the range, carry out a provisional test (see "Testing" chapter), positioning yourself, first, near the automation and then near the place of final installation.

Though the range under favourable conditions, in a free field, can be 100-200 m, taking into account the protection function, we advise you not to exceed 20-30 m. Moreover, you should make sure that there are no other devices operating at the same frequency and with continuous transmission, such as alarms, headphones, etc., which might further reduce the range.

For proper operation, keep in mind that the weather sensor must be positioned near the shutter/awning to be protected, in an area that is exposed to the action of the wind and sun.

To proceed with the installation, refer to Fig. 2, Fig. 3, Fig. 4 and Fig. 7; remember not to tighten the fastening screw too hard (Fig. 1, detail A).

⚠ As SKIROSOL SRCK 610 is supplied with mains voltage, we recommend that you do not install it in an easily accessible location.

3) Electrical connections

The product must be connected to a 230Vac (SKIROSOL SRCK 610 version) or 120Vac power source (SKIROSOL SRCK 610-V1 version), without ground connection, as shown in Fig.5, Fig.6 and Fig.7.

After wiring, close the covers on the mounting bracket securely (Fig.1 detail D).

4) Testing

When the sensor is powered, the following events will take place:





- Power ON audible signal (4 Beeps )
- RED light flashes (pre-programmed = 3 ) , corresponding to the set WIND level, than GREEN light flashes (pre-programmed = 3 ) , corresponding to the set SUN level.

Table "A"	Switching on	Example
1.	As soon as the control unit is powered, you will hear 4 beeps.	
2.	The Wind level is indicated by a few RED light flashes.	
3.	The Sun level is indicated by a few GREEN light flashes.	

For the correspondence between the number of flashes and the value of the levels see Tables B1 and B2.

The following description refers to the use of a motor for awning automation; however, this procedure can also be used for the other applications. To make sure that the sensor has been installed properly, follow the steps listed below.

4.1) Memorizing the code

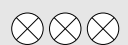















In order for the commands transmitted by the sensor to have effect on the motors and/or control units, the code must be memorized just like for a remote control. In fact, each remote control is recognized by the receiver through a "code" that differs from all the other codes. Therefore, a memorization stage is required, enabling the receiver to recognize each single radio control. Button () must be pressed to enable the use of the device as a remote control: you will hear a beep () and, after about 1 second, the RED LED will start flashing, indicating that the device is transmitting. The transmission takes place while the button is being pressed. The transmission lasts approximately 12s max. The memorization procedure depends on the type of receiver used: see the instructions for the receiver. Most automations adopt the following procedure: when the memory contains no codes, the first radio control can be memorized following the procedure detailed in table A1; however, if one or more transmitters have already been memorized, additional ones can be enabled following the instructions in Table A2.

Table "A1"	Memorizing the first transmitter	Example
1.	As soon as the control unit is powered, you will hear 2 long beeps.	"ON"  5s
2.	Within 5 seconds, press and hold down button  on the transmitter to be memorized (for about 3 seconds).	 3s
3.	Release button  when you hear the first of the 3 beeps confirming the memorisation.	 

Note: If the control unit already contains codes, 2 short beeps will be heard when it is switched on. This means that the above procedure is not valid and you will have to proceed as described in Table "A2".

Table "A2"	Memorizing other transmitters	Example
1.	Press and hold down button  on the new transmitter until you hear a beep (after about 5 seconds).	New  5s 
2.	Press slowly 3 times button  on a previously enabled transmitter (old).	Old  X3
3.	Press button  on the new transmitter once more.	New 
4.	Finally, 3 beeps will signal that the new transmitter has been correctly memorized.	

Note: if the memory is full, 6 beeps will indicate that the transmitter cannot be memorized.

4.2) Testing the WIND sensor

- Position the awning at an intermediate point between the open and closed positions.
- Blow air on the anemometer to make it turn (you can use a hair dryer) at a speed that exceeds the programmed threshold (the factory setting is 15 Km/h, corresponding to approximately 4 rev/sec).
- After the WIND threshold has been exceeded for at least 3 seconds, movement should start in the direction corresponding to remote control key . The RED LED will flash, indicating that the command has actually been transmitted.

4.3) Testing the SUN sensor

- Disconnect and reconnect the power supply to the motor and sensor.
- Position the awning at an intermediate point between the open and closed positions.
- Illuminate the sensor using a light source (sun or lamp) with a brightness that exceeds the programmed threshold (the factory setting is 10 KLux, corresponding to the SUN of a clear sunny day).
- After 2 minutes, a manoeuvre corresponding to remote control key  should start. The GREEN LED will flash, indicating that the command has actually been transmitted.

5) Programming

If the SUN or WIND cut-in levels are not suitable for the application, they can be modified according to your requirements (awning dimensions, position, weather requirements). The SUN and WIND cut-in levels can be modified separately using button (); you can select from 5 WIND values and 6 SUN values, as shown in Tables B1 and B2.

Table "B1" WIND levels
Level N. 1 = 5 Km/h
Level N. 2 = 10 Km/h
Level N. 3 = 15 Km/h
Level N. 4 = 30 Km/h
Level N. 5 = 45 Km/h

Table "B2" SUN levels
Level N. 1 = 2 KLux
Level N. 2 = 5 KLux
Level N. 3 = 10 KLux
Level N. 4 = 20 KLux
Level N. 5 = 40 KLux
Level N. 6 = Current KLux value
Level N. 7 = Delete

Note: In the programming of SUN level 6, the brightness value measured at the time of programming is memorized

To modify the cut-in levels, follow the instructions in Tables C1 and C2.





































Table "C1" Modifying the "WIND" protection cut-in level (Fig.8)	Example
1. Press and release the button. When the button is released, the RED LED lights up and stays on, indicating the WIND programming stage.	  
2. Wait until you hear a beep.	 
3. Within 4 seconds press and release the button 1 to 5 times according to the desired level (see Table B1).	 X1 = 5 Km/h X2 = 10 Km/h X3 = 15 Km/h X4 = 30 Km/h X5 = 45 Km/h
4. After a few seconds you will hear a number of beeps, accompanied by RED flashes, corresponding to the set WIND level; subsequently, the RED LED will stay on.	X1 = 5 Km/h X2 = 10 Km/h   X3 = 15 Km/h X4 = 30 Km/h X5 = 45 Km/h
5. Within 4 seconds, press the button once to confirm; you will hear three long beeps and the LED will go off.	   
Note 1 If, for any reason, you should make a mistake in the programming, a series of short beeps and flashes will signal the fact.	    
Note 2 When the programming procedure has been completed, the set levels will be indicated by a corresponding number of RED flashes (WIND) followed by GREEN flashes (SUN).	

Table "C2" Change or delete the level of the "sun" (Fig.9)	Example
1. Press and release the button twice. When the button is released, the GREEN LED lights up and stays on, indicating the SUN programming stage.	    
2. Wait until you hear a beep.	 
3. Within 4 seconds press and release the button 1 to 7 times according to the desired level (see Table B2).	 X1 = 2 KLux X2 = 5 KLux X3 = 10 KLux X4 = 20 KLux X5 = 40 KLux X6 = Auto X7 = Delete
4. After a few seconds you will hear a number of beeps, accompanied by GREEN flashes, corresponding to the set SUN level; subsequently, the GREEN LED will stay on.	X1 = 2 KLux X2 = 5 KLux X3 = 10 KLux   X4 = 20 KLux X5 = 40 KLux X6 = Auto X7 = Delete
5. Within 4 seconds, press the button once to confirm; you will hear three long beeps and the LED will go off.	   
Note 1 If, for any reason, you should make a mistake in the programming, a series of short beeps and flashes will signal the fact.	    
Note 2 When the programming procedure has been completed, the set levels will be indicated by a corresponding number of RED flashes (WIND) followed by GREEN flashes (SUN). (7 flashes indicate "Delete")	

6) What to do if...

Even if the anemometer turns at a speed exceeding the programmed level, the motors do not carry out the “up” command (▲).

Check the voltage supplied to the sensor connection terminals, it should correspond to the nominal value. If you measure a different value, check the connections, see whether the motor is running; make sure you have memorized the sensor code in each motor or control unit you wish the sensor to control.

Though the connections are OK and the voltage reading on the sensor connection is correct, when the anemometer turns the “up” manoeuvre (▲) is not carried out.

The WIND protection cut-in level must be exceeded for at least 3 seconds; make the anemometer turn at an appropriate speed; you could try lowering the WIND protection cut-in level of the sensor; check the flashing of the RED LED, indicating that the command is transmitted.

The WIND response test has been carried out successfully, unlike the SUN response test.

The SUN protection “down” manoeuvre is ordered only once when the programmed level is exceeded for at least 2 minutes. Try switching the motor and sensor off and back on again, then repeat the test. You could also try lowering the SUN protection cut-in level. Check the flashing of the GREEN LED, indicating that the command is transmitted.

The sensor is working but its radio range is inadequate.

Make sure that there are no other devices operating at the same frequency and with continuous transmission, such as alarms, headphones, etc., which might reduce the range.

7) Technical characteristics

General characteristics

Mains power supply	SKIROSOL SRCK 610	230 Vac 50/60 Hz 1.5W
	SKIROSOL SRCK 610-V1	120 Vac 50/60 Hz 1.5W
Transmission Frequency	433.92 MHz	LPD device with incorporated aerial
Radiated Power	Approx. 1 mW (e.r.p.)	Under optimum conditions it corresponds to a range of approx. 100-200m
IP protection	IP 44	
Operating temperature	-20 °C ÷ +55 °C	
Container	Dimensions	W = 120 mm L = 215 mm H = 85 mm
	Weight	P = 250 g

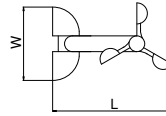

Sensor characteristics

Anemometer	Range	0-127 Km/h
	Resolution	1 Km/h
	Conversion constant	0.26 $\frac{\text{Rev} / \text{s}}{\text{Km} / \text{h}}$
	Accuracy	± 2 % F.S.
	Programmable levels	Level 1 = 5 Km/h Level 2 = 10 Km/h Level 3 = 15 Km/h Level 4 = 30 Km/h Level 5 = 45 Km/h
Luxmeter	Range	0 ÷ 64 KLux
	Resolution (KLux)	0 - 10 KLux: 0.25 KLux 10 - 40 KLux: 0.5 KLux 40 - 64 KLux: 1 KLux
	Accuracy	± 10% F.S.
	Programmable levels	Level 1 = 2 KLux Level 2 = 5 KLux Level 3 = 10 KLux Level 4 = 20 KLux Level 5 = 40 KLux Level 6 = AUTO Level 7 = DELETE

Subject to change without prior notification.

Advertencias:

Para la instalación, mantenimiento y reparación del producto, diríjase exclusivamente a personal técnico capacitado, el que debe realizar tales trabajos respetando las normas vigentes.

⚠ Lea con atención las instrucciones y compruebe cuáles son los motores o centrales que pueden utilizarse con el sensor climático SKIROSOL SRCK 610. Cualquier otro uso es considerado inadecuado y está prohibido

1) Descripción del producto

El sensor climático SKIROSOL SRCK 610 mide la velocidad del VIENTO en km/h y la intensidad de la luz solar en KLux.

Se lo puede utilizar para accionar motores o centrales adecuados, permitiendo automatizar el movimiento de toldos, persianas y similares por medio del accionamiento por radio, en función de las condiciones atmosféricas detectadas. Por ejemplo, si se trata de un toldo, el sensor lo abre al superarse el nivel de SOL y lo cierra al superarse el nivel de VIENTO. Los mandos son transmitidos por radio, es decir que las únicas conexiones que se han de hacer son aquellas a la línea eléctrica (véase el Capítulo "Instalación").

SKIROSOL SRCK 610 tiene un botón (Fig.1 detalle B) de programación o transmisión (Fig.1 detalle B), y un indicador luminoso (LED) multicolor (Fig.1 detalle C); también posee un tono de aviso (Bip).

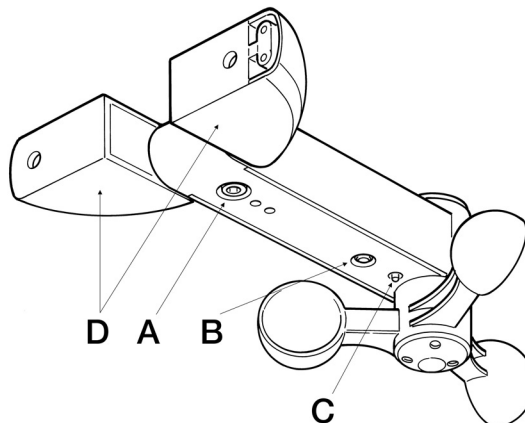

1.1) Reglas de mando

SKIROSOL SRCK 610 mide la velocidad del VIENTO y la intensidad del SOL y, cuando el valor supera el nivel programado, envía un mando a los motores o centrales, tal como especificado a continuación:

Viento: cuando se supera el nivel de "VIENTO" durante 3 segundos como mínimo, envía un mando de "subida" que equivale al botón ▲ de los controles remotos. Al superar el umbral, la luz del LED se vuelve roja y durante la transmisión del mando, el LED parpadea con luz ROJA.

Sol: cuando se supera el nivel de "SOL" durante 2 minutos como mínimo, envía un mando de "bajada" que equivale al botón ▼ de los controles remotos. Al superar el umbral, la luz del LED se vuelve VERDE y durante la transmisión del mando, el LED parpadea con luz VERDE.

Prioridades: De superarse ambos niveles, la prioridad se da al "VIENTO" respecto del "SOL", según un principio de seguridad.

Solamente después de pasados 2 minutos como mínimo desde la conclusión de "VIENTO", puede accionarse el "SOL" con su regla.

Cada mando se repite periódicamente hasta que no se supere más el nivel.

SKIROSOL SRCK 610 también transmite los datos medidos de velocidad del VIENTO en km/h, la intensidad luminosa del SOL en Klux, presencia de LLUVIA*, TEMPERATURA*, HUMEDAD*.

(* = sólo para versiones que incorporen el sensor respectivo)

2) Instalación

Antes de efectuar la instalación, se recomienda comprobar el alcance radio, porque la presencia de paredes gruesas o de otros dispositivos que funcionen a la misma frecuencia pueden reducir mucho su alcance. Para verificarlo, realice un ensayo transitorio (véase el capítulo "Ensayo") situándose primero cerca de la automatización y, después, cerca del punto de instalación definitivo. Aunque el alcance en condiciones favorables, campo libre, puede ser de 100-200 m, considerando la función de protección se recomienda no superar los 20-30 m. También se recomienda controlar que no haya dispositivos que funcionen en la misma frecuencia y con transmisiones continuas tales como alarmas, auriculares con radio, etc. que podrían reducir posteriormente el alcance.

Para el funcionamiento correcto del sensor climático, se recuerda que éste debe colocarse cerca de la persiana/toldo a proteger y en una zona expuesta a la acción del viento y del sol.

Para proceder con la instalación, refiérase a las Fig.2, Fig.3, Fig.4 y Fig.7, recordándose de no apretar con fuerza el tornillo de fijación (Fig.1 detalle A).

⚠ Puesto que SKIROSOL SRCK 610 es alimentado a la tensión de red, se recomienda instalarlo en un punto que no sea fácilmente accesible.

3) Conexiones eléctricas

El producto debe conectarse a una alimentación a 230 Vca (versión SKIROSOL SRCK 610), o a 120Vca (versión SKIROSOL SRCK 610-V1), sin conexión a tierra, tal como muestran las Fig.5, Fig.6 y Fig.7.

Concluido el cableado, cierre con cuidado la tapa del soporte de fijación (Fig.1 detalle D).

4) Ensayo

Conectando la tensión al sensor, se producirán las siguientes acciones.





- tono de aviso de encendido (4 Bips )
- algunos parpadeos con luz ROJA (predeterminado = 3 ) , equivalentes al nivel de VIENTO configurado, después algunos parpadeos con luz VERDE (predeterminado = 3 ) , equivalentes al nivel de SOL configurado.

Tabla "A"	Encender	Ejemplo
1.	Ni bien se conecta la alimentación a la central, se oirán 4 tonos de aviso.	
2.	Indicación del nivel Viento mediante algunos parpadeos con luz ROJA.	
3.	Indicación del nivel Sol mediante algunos parpadeos con luz VERDE.	

Para las correspondencias entre número de parpadeos y valor de los niveles, véanse las Tablas B1 y B2.

En la siguiente descripción se tomará como referencia un motor para toldos, procedimientos similares podrán aplicarse a los demás casos. Para verificar la instalación correcta del sensor, siga estos pasos.

4.1) Memorización del código

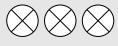











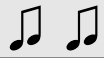



Para que los mandos enviados por el sensor tengan efecto sobre los motores o sobre las centrales, hay que memorizar el código igual que en un control remoto. En efecto, cada control remoto es reconocido por el receptor a través de un "código" diferente de cualquier otro. Por eso se requiere una etapa de "memorización" en la que se prepara al receptor para que reconozca cada uno de los radiomandos. Para utilizarlo como control remoto se presiona el botón () : se oirá un tono de aviso () y, transcurrido alrededor de 1 segundo, el LED parpadeará con luz ROJA, indicando que transmite; la transmisión continúa mientras se tiene apretado el botón. La transmisión dura alrededor de 12s como máximo. El procedimiento de memorización depende del receptor empleado, por lo que deben consultarse las instrucciones respectivas. La mayor parte de las automatizaciones sigue el siguiente procedimiento: cuando la memoria no contiene ningún código se puede comenzar a memorizar el primer radiomando con el método de la Tabla A1, por el contrario, si uno o varios transmisores han sido memorizados, es posible activar otros con el método de la Tabla A2.

Tabla "A1"	Memorización del primer transmisor	Ejemplo
1.	Ni bien se conecta la alimentación a la central, se oirán 2 tonos de aviso largos.	"ON"  5s
2.	Antes de transcurridos 5 segundos, oprima y mantenga apretado el botón  del transmisor a memorizar (durante alrededor de 3 segundos).	 3s
3.	Suelte el botón  cuando oiga el primero de los 3 tonos de aviso que confirman la memorización.	 

Nota: si la central ya contiene códigos, en el momento del encendido se oirán 2 tonos de aviso cortos y no se podrá proceder como descrito, sino que habrá que usar el otro método de memorización (Tabla "A2").

Tabla "A2"	Memorización de otros transmisores	Ejemplo
1.	Mantenga apretado el botón  del transmisor nuevo hasta oír un tono de aviso (después de alrededor de 5 segundos)	Nuevo  5s 
2.	Oprima lentamente 3 veces el botón  de un transmisor habilitado (viejo).	Viejo  X3
3.	Oprima de nuevo el botón  del transmisor nuevo.	Nuevo 
4.	Al final, 3 tonos de aviso le indicarán que el transmisor nuevo ha sido memorizado correctamente.	

Nota: si la memoria está llena, 6 tonos de aviso le indicarán que el transmisor no puede ser memorizado.

4.2) Control del sensor VIENTO

- Coloque el toldo en un punto intermedio entre la apertura y el cierre.
- Haga girar el anemómetro (utilizando si fuera necesario un secador de cabellos) a una velocidad superior al límite configurado en el motor (el nivel configurado en fábrica es de 15 km/h que corresponde a alrededor de 4 vueltas/segundo).
- Después de haber superado el límite durante 3 segundos como mínimo, debe comenzar la maniobra en la dirección que equivale al botón  de los controles remotos. Se observará la luz ROJA intermitente, que indica la transmisión efectiva del mando.

4.3) Control del sensor SOL

- Corte y active de nuevo la alimentación al motor y al sensor.
- Coloque el toldo en un punto intermedio entre la apertura y el cierre.
- Ilumine el sensor con una fuente luminosa (sol o lámpara) con una intensidad superior al límite configurado (el nivel configurado en fábrica es de 10KLux, que corresponde al SOL de una mañana serena).
- Transcurridos 2 minutos debe iniciar una maniobra equivalente al botón  de los controles remotos. Se observará la luz VERDE intermitente, que indica la transmisión efectiva del mando.

5) Programaciones

Si los niveles de activación de SOL o VIENTO no son adecuados para la aplicación, es posible modificarlos según las exigencias personales (tamaño del toldo, posición, exigencia atmosférica). Los niveles de activación del SOL y del VIENTO pueden modificarse individualmente con el botón (), seleccionando entre 5 valores de VIENTO y 6 de SOL, tal como indicado en las Tablas B1 y B2.

Tabla "B1" Niveles de VIENTO
Nivel N° 1 = 5 Km/h
Nivel N° 2 = 10 Km/h
Nivel N° 3 = 15 Km/h
Nivel N° 4 = 30 Km/h
Nivel N° 5 = 45 Km/h

Tabla "B2" Niveles de SOL
Nivel N° 1 = 2 KLux
Nivel N° 2 = 5 KLux
Nivel N° 3 = 10 KLux
Nivel N° 4 = 20 KLux
Nivel N° 5 = 40 KLux
Nivel N° 6 = Valor actual KLux
Nivel N° 7 = Desconexión

Nota: en la programación del nivel 6 del SOL se memoriza el valor de luminosidad medido en ese instante.

Para cambiar los niveles de activación, siga las indicaciones de las Tablas C1 y C2.



















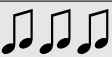















Tabla "C1" Cambio del nivel de activación de la protección "VIENTO" (Fig. 8)	Ejemplo
1. Oprima y suelte el botón. Al soltarlo, el LED se enciende y queda encendido con luz ROJA, indicando la etapa de programación VIENTO.	  
2. Espere hasta que oiga un tono de aviso.	 
3. Dentro de 4 segundos, presione y suelte el botón entre 1 y 5 veces, según el nivel escogido (véase la Tabla B1).	 X1 = 5 Km/h X2 = 10 Km/h X3 = 15 Km/h X4 = 30 Km/h X5 = 45 Km/h
4. Transcurrido un instante, se oirá un número de tonos de aviso, acompañados de parpadeos con luz ROJA, equivalentes al nivel de VIENTO configurado; después el LED quedará encendido con luz ROJA.	X1 = 5 Km/h X2 = 10 Km/h   X3 = 15 Km/h X4 = 30 Km/h X5 = 45 Km/h
5. Antes de transcurridos 4 segundos oprima 1 vez el botón. Para confirmar, se oirán 3 tonos de aviso largos y el LED se apagará.	 
Nota 1 Si por algún motivo se cometiera un error en la programación, transcurridos algunos instantes usted oirá una serie de tonos de aviso y parpadeos breves.	     
Nota 2 Al concluir la programación, el LED indicará los niveles configurados: mediante parpadeos con luz ROJA equivalente al nivel de VIENTO configurado; seguido por parpadeos con luz VERDE equivalentes al nivel de SOL configurado.	

Tabla "C2" Cambie o desconecte el nivel de activación del "sol" (Fig. 9)	Ejemplo
1. Oprima y suelte el botón dos veces. Al soltarlo, el LED se enciende y queda encendido con luz VERDE, indicando la etapa de programación de SOL.	     
2. Espere hasta que oiga un tono de aviso.	 
3. Dentro de 4 segundos, presione y suelte el botón entre 1 y 7 veces, según el nivel escogido (véase la Tabla B2).	 X1 = 2 KLux X2 = 5 KLux X3 = 10 KLux X4 = 20 KLux X5 = 40 KLux X6 = Auto X7 = Desconexión
4. Transcurrido un instante, se oirá un número de tonos de aviso, acompañados de una cantidad de parpadeos con luz VERDE equivalente al nivel de SOL configurado; después el LED quedará encendido con luz VERDE.	X1 = 2 KLux X2 = 5 KLux   X3 = 10 KLux X4 = 20 KLux X5 = 40 KLux X6 = Auto X7 = Desconexión
5. Antes de transcurridos 4 segundos oprima 1 vez el botón. para confirmar, se oirán 3 tonos de aviso largos y el LED se apagará.	 
Nota 1 Si por algún motivo se cometiera un error en la programación, transcurridos algunos instantes usted oirá una serie de tonos de aviso y parpadeos breves.	     
Nota 2 Al concluir la programación, el LED indicará los niveles configurados: mediante parpadeos con luz ROJA equivalentes al nivel de VIENTO configurado; seguido por parpadeos con luz VERDE equivalentes al nivel de SOL configurado. (7 parpadeos indican la desconexión)	

6) Qué hacer si...

Incluso si se hace girar el anemómetro a una velocidad superior al nivel programado, los motores conectados no cumplen con el mando de "subida" (▲).

Controle la tensión que hay en los cables de conexión del sensor, que debe ser equivalente al valor nominal. Si el valor fuera diferente, controle las conexiones, controle que el motor funcione; controle que haya sido memorizado el código de cada motor o central que se quiere accionar con el sensor.

Las conexiones son correctas y se mide una tensión de red regular en la conexión del sensor, pero al hacer girar el anemómetro no se activa la maniobra de subida (▲).

El nivel de activación para la protección VIENTO se debe superar durante 3 segundos como mínimo; haga girar el anemómetro a una velocidad adecuada; si fuera necesario, pruebe a bajar el límite de activación del VIENTO en el sensor, controle el parpadeo del LED con luz ROJA que indica la transmisión del mando.

El control del funcionamiento de VIENTO ha dado resultados positivos, pero no así el control de la activación de SOL.

La maniobra de bajada para sol se acciona sólo 1 vez cuando se supera el límite configurado durante 2 minutos como mínimo. Pruebe a apagar y encender de nuevo el motor y repita el ensayo; si fuera necesario, baje el nivel de activación del SOL. Controle el parpadeo del LED con luz VERDE, que indica la transmisión efectiva del mando.

El sensor funciona, pero no tiene alcance radio.

Controle que no haya otros dispositivos que funcionen en la misma frecuencia y con transmisiones continuas tales como alarmas, auriculares con radio, etc. que podrían reducir posteriormente el alcance

7) Características técnicas

Características generales

Alimentación de red	SKIROSOL SRCK 610	230 Vac 50/60 Hz 1.5W
	SKIROSOL SRCK 610-V1	120 Vac 50/60 Hz 1.5W
Frecuencia de transmisión	433.92 MHz	LPD con antena integrada
Potencia irradiada	Aprox 1 mW (e.r.p.)	En condiciones ideales corresponde a un alcance de alrededor de 100-200 m
Protección IP	IP 44	
Temperatura de funcionamiento	-20 °C ÷ +55 °C	
Caja	Dimensiones	W = 120 mm L = 215 mm H = 85 mm
	Peso	P = 250 g

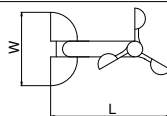

Características sensores

Anemómetro	Rango	0-127 Km/h
	Resolución	1 Km/h
	Constante de conversión	0.26 $\frac{\text{Rev}}{\text{s}}$ Km / h
	Precisión	± 2 % F.S.
	Niveles programables	Niv 1 = 5 Km/h Niv 2 = 10 Km/h Niv 3 = 15 Km/h Niv 4 = 30 Km/h Niv 5 = 45 Km/h
Luxmetro	Rango	0 ÷ 64 KLux
	Resolución (KLux)	0 - 10 KLux: 0.25 KLux 10 - 40 KLux: 0.5 KLux 40 - 64 KLux: 1 KLux
	Precisión	± 10% F.S.
	Niveles programables	Niv 1 = 2 KLux Niv 2 = 5 KLux Niv 3 = 10 KLux Niv 4 = 20 KLux Niv 5 = 40 KLux Niv 6 = AUTO Niv 7 = DESCONEXIÓN

Reservado el derecho de modificaciones.

Waarschuwingen:

Installatie, onderhoud en reparatie van het product moeten uitsluitend door vakbekwaam technisch personeel uitgevoerd worden met volledige inachtneming van de vigerende wettelijke voorschriften.

⚠ Lees de instructies goed en controleer welke motoren of regeleenheden gebruikt kunnen worden met de klimaatsensor SKIROSOL SRCK 610. Elk ander gebruik is oneigenlijk en verboden.

1) Productbeschrijving

De klimaatsensor SKIROSOL SRCK 610 meet de snelheid van WIND in Km/h en de zonlichtsterkte in Klux.

Hij kan gebruikt worden om daarop ingestelde motoren of regeleenheden te bedienen, zodat de beweging van zonneschermen, rolgordijnen en dergelijke geautomatiseerd kan worden via radiobesturing, op basis van de gemeten weersomstandigheden. Een zonneschermbeweging gaat bijvoorbeeld open bij overschrijding van het lichtsterkeniveau van de ZON en bij overschrijding van het WIND niveau dicht. De opdrachten worden via radio verzonden, dus hoeven alleen de aansluitingen op de elektrische leiding verricht te worden (zie Hoofdstuk "Installatie").

SKIROSOL SRCK 610 is voorzien van een programmeer- of zendknopje (Afb.1 detail B), en een veelkleurig lichtsignaal (Led ⊗) (Afb.1 detail C); er is bovendien een geluidssignaal (Beep ♪).

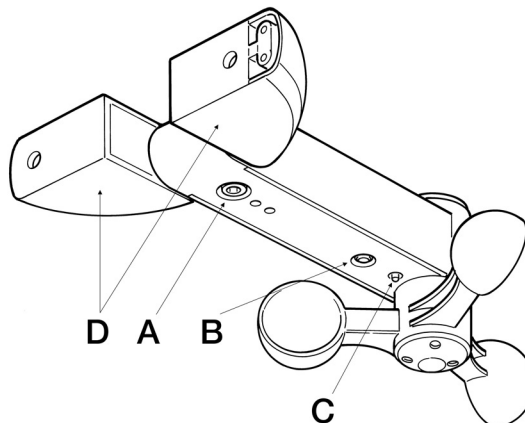

1.1) Bedieningstregels

SKIROSOL SRCK 610 meet de WINDsnelheid en ZONsterkte, wanneer de waarde het geprogrammeerde niveau overschrijdt, wordt een als volgt gespecificeerde opdracht verstuurd naar de motoren of regeleenheden:

Wind: Wanneer het "WIND" niveau tenminste 3 seconden lang overschreden is, zendt hij een "omhoog" opdracht, overeenkomende met toets ▲ van de afstandsbedieningen. Bij overschrijding van de drempel wordt het ledlampje ROOD en tijdens de verzending van de opdracht knippert de Led met ROOD licht.

Zon: Wanneer het "ZON" niveau tenminste 2 minuten lang overschreden is, zendt hij een "omlaag" opdracht, overeenkomende met toets ▼ van de afstandsbedieningen. Bij overschrijding van de drempel wordt het ledlampje GROEN en tijdens de verzending van de opdracht knippert de Led met GROEN licht.

Precedenze: indien beide niveaus overschreden zijn, wordt aan de "WIND" sensor voorrang gegeven boven de "ZON" sensor, overeenkomstig een veiligheidsprincipe. Pas nadat "WIND" tenminste 2 minuten lang opgehouden is, kan "ZON" met zijn eigen regel in werking treden.

Iedere opdracht wordt periodiek herhaald totdat het niveau niet meer overschreden wordt.

SKIROSOL SRCK 610 zendt bovendien de gemeten WINDsnelheid in Km/h, de gemeten lichtsterkte van de ZON in Klux, de aanwezigheid van REGEN*, TEMPERATUUR*, VOCHT**.

(* = alleen voor uitvoeringen met desbetreffende sensor)

2) Installatie

Alvorens tot de installatie over te gaan, wordt aangeraden het zendbereik van de radio te verifiëren, aangezien de aanwezigheid van dikke muren en/of andere inrichtingen op dezelfde frequentie het bereik aanzienlijk kunnen verminderen. Voer een voorlopige test uit om dit na te gaan (zie Hoofdstuk "Test") en ga eerst bij het automatische staan en vervolgens bij het definitieve installatiepunt. Hoewel het zendbereik in gunstige omstandigheden 100-200 m zijn kan, verdient het vanwege de beveiligingsfunctie aanbeveling de afstand van 20-30 m niet te overschrijden. Tevens wordt aanbevolen na te gaan of er geen andere inrichtingen, zoals alarminstallaties, radiokoptelefoons enz... die het bereik nog meer kunnen verminderen, op dezelfde frequentie en met ononderbroken zendingen werken. Denk eraan dat de klimaatsensor om goed te kunnen werken in de nabijheid van het te beschermen rolgordijn geplaatst moet worden en op een aan de werking van wind en zon blootgestelde plaats.

Raadpleeg afb. 2, 3, 4 en 7 voor de installatie. Haal de bevestigingschroef niet te strak aan (afb. 1, detail A).

⚠ Aangezien SKIROSOL SRCK 610 gevoed wordt door het elektriciteitsnet, wordt aangeraden deze op een niet gemakkelijk toegankelijk punt te plaatsen.

3) Elektrische aansluitingen



Het product moet aangesloten worden op een stroomvoorziening van 230 Vac (versie SKIROSOL SRCK 610) of 120 Vac (versie SKIROSOL SRCK 610-VI), zonder aardeverbinding, zoals aangegeven in Afb. 5, 6 en 7.

Sluit de deksels van de bevestigingsbeugel zorgvuldig nadat de bedrading tot stand gebracht is (Afb. 1, detail D).

4) Test

Wanneer de sensor onder spanning gezet wordt, gebeurt het volgende:



- geluidssignaal bij het aanzetten (4 Bieptonen )
- ROOD knipperlicht(voorgeprogrammeerd = 3 ) , gelijk aan ingestelde WIND niveau, vervolgens GROEN knipperlicht (voorgeprogrammeerd = 3 ) , gelijk aan ingestelde ZON niveau.







Tabel "A"	Aanzetten	Voorbeeld
1.	Zodra de regeleenheid elektrisch gevoed is, hoort u 4 Bieptonen.	
2.	Signalering van het Wind niveau via een aantal knipperen van ROOD licht.	
3.	Signalering van het Zon niveau via een aantal knipperen met GROEN licht.	

Voor het verband tussen aantal knipperen en niveauwaarde wordt verwezen naar Tabel B1 en B2.







Onderstaande beschrijving betreft het gebruik van een motor voor zonnescermen, in andere gevallen kunnen analoge procedures gevolgd worden. Volg onderstaande stappen om te controleren of de sensor goed geïnstalleerd is.

4.1) Code in het geheugen opslaan

Opdat de naar de sensor gezonden opdrachten een uitwerking kunnen hebben op de motoren en/of regeleenheden, moet de code in het geheugen opgeslagen worden, net zoals in een afstandsbediening. Elke afstandsbediening wordt via een van alle andere verschillende "code" herkend door de ontvanger. Daarom is een "opslag" fase noodzakelijk waarin de ontvanger ingesteld wordt op het herkennen van elke afzonderlijke radiobesturing. Hij wordt gebruikt als een afstandsbediening door op het knopje () te drukken. U hoort een biepton () en u ziet na ongeveer 1 seconde dat de Led met ROOD licht gaat knipperen, ten teken dat hij aan het zenden is. De zending vindt plaats zolang de toets ingedrukt blijft en duurt hoogstens ongeveer 12 seconden. De opslagprocedure hangt af van de gebruikte ontvanger. Raadpleeg daarom de instructies voor de ontvanger. Het merendeel van de automatisen volgt de volgende procedure: indien het geheugen geen enkele code bevat, kan men voor de invoering van de eerste radiobesturing te werk gaan volgens Tabel A1, anders, indien er reeds een of meerdere zenders in het geheugen opgeslagen zijn, kunnen er andere ingeschakeld worden volgens Tabel A2.

Tabel "A1"	Eerste zender wordt in het geheugen opgeslagen	Voorbeeld
1.	Zodra de regeleenheid elektrisch gevoed is, hoort u 2 lange bieptonen.	"ON"  5s
2.	Druk binnen 5 seconden op toets  van de zender die opgeslagen moet worden en houd deze (ongeveer 3 seconden lang) ingedrukt.	 3s
3.	Laat toets  los wanneer u de eerste van de 3 bieptonen hoort die het opslaan bevestigen.	 

Opmerking: Indien de regeleenheid reeds codes bevat, hoort u bij het aanwetten 2 korte bieptonen en kunt u niet op de hierboven beschreven wijze te werk gaan, maar moet u de andere wijze van opslaan volgen (Tabel "A2").

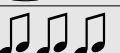
Tabel "A2"	Het in het geheugen opslaan van andere zenders	Voorbeeld
1.	Houd toets  van de nieuwe zender ingedrukt totdat u (na ongeveer 5 seconden) een biepton hoort.	Nieuw  5s 
2.	Druk langzaam 3 keer op toets  van een reeds ingeschakelde (oude)	Oude  X3
3.	Druk nogmaals op toets  van de nieuwe zender.	Nieuw 
4.	Aan het einde signaleren 3 bieptonen dat de nieuwe zender goed opgeslagen is.	

Opmerking: Indien het geheugen vol is, signaleren 6 Bieptonen dat de zender niet Opgeslagen kan worden.

4.2) Controle WIND sensor

- Plaats het zonnescerm op een punt tussen open en dicht.
- Laat de anemometer draaien (eventueel met beulp van een haardroger) op een snelheid boven het ingestelde niveau (het door de fabriek ingestelde niveau is 15 km/h, hetgeen overeenkomt met ongeveer 4 omwentelingen per seconde).
- Nadat het WIND niveau tenminste 3 seconden lang overschreden is, moet een manoeuvre van start gaan in de richting die overeenkomt met toets  van de afstandsbesturingen. U ziet ROOD licht knipperen, ten teken dat de opdracht inderdaad verzonden is.

4.3) Controle ZON sensor

- Zet motor en sensor uit en weer aan.
- Plaats het zonnescerm op een punt tussen dicht en open.
- Verlicht de sensor met een lichtbron (zon of lamp) met een lichtsterkte die groter is dan de ingestelde waarde (het door de fabriek ingestelde niveau is 10 KLux, overeenkomend met de ZON op een heldere ochtend).
- Na 2 minuten moet een manoeuvre van start gaan die overeenkomt met toets  van de afstandsbedieningen. U ziet GROEN licht knipperen ten teken dat de opdracht inderdaad verzonden is.

5) Programmeringen















Indien de inwerkingtredeingsniveaus van de ZON- of WINDsensoren niet geschikt zijn voor de toepassing, kunnen deze naar eigen behoefte gewijzigd worden (afmetingen zonnenscherm, positie, weersomstandigheden). De inwerkingtredeingsniveaus van de ZON- en WIND sensoren kunnen afzonderlijk gewijzigd worden via het knopje (🔽), waarbij u kunt kiezen tussen 5 WIND niveaus en 6 ZON niveaus, zoals aangegeven in Tabel B1 en B2.

Tabel "B1" WINDniveaus
Niveau N° 1 = 5 Km/h
Niveau N° 2 = 10 Km/h
Niveau N° 3 = 15 Km/h
Niveau N° 4 = 30 Km/h
Niveau N° 5 = 45 Km/h

Tabel "B2" ZONniveaus
Niveau N° 1 = 2 KLux
Niveau N° 2 = 5 KLux
Niveau N° 3 = 10 KLux
Niveau N° 4 = 20 KLux
Niveau N° 5 = 40 KLux
Niveau N° 6 = Huidige waarde KLux
Niveau N° 7 = Uitsluiting

Opmerking: Bij de programmering van niveau 6 van de ZON sensor, wordt de op dat moment gemeten lichtsterkte waarde in het geheugen opgeslagen.

Volg de aanwijzingen van Tabel C1 en C2 om de inwerkingtredeingsniveaus te veranderen.

Tabel "C1" Inwerkingtredeingsniveau "WIND" beveiliging veranderen. (Afb. 8)	Voorbeeld
1. Druk op het knopje en laat het weer los. Bij het loslaten gaat de Led branden en blijft branden met ROOD licht, ten teken dat WIND in programmeerfase is.	  
2. Wacht totdat u een Beeptoon hoort.	 
3. Druk binnen 4 seconden 1 tot 5 keer, afhankelijk van het gekozen niveau, op het knopje en laat het weer los (zie Tabel B1).	 X1 = 5 Km/h X2 = 10 Km/h X3 = 15 Km/h X4 = 30 Km/h X5 = 45 Km/h
4. Na enkele ogenblikken hoort u een aantal Beep-tonen, gelijk aan het ingestelde WIND niveau begeleid door ROOD knipperlicht. Daarna blijft de LED met ROOD licht branden.	X1 = 5 Km/h X2 = 10 Km/h   X3 = 15 Km/h X4 = 30 Km/h X5 = 45 Km/h
5. Druk binnen 4 seconden 1 keer op het knopje ter bevestiging, u hoort drie lange Beep-tonen en de Led gaat uit.	 
Opmerking 1 Indien er om welke reden ook een fout begaan wordt in de programmering, hoort u na enkele ogenblikken een reeks korte Beep-tonen en knipperlichten.	      
Opmerking 2 Aan het einde van de programmering worden de ingestelde niveaus aangegeven met lichtsignalen, met ROOD licht dat evenveel keren knippert als het ingestelde WIND niveau is, met GROEN licht voor de ingestelde ZONlichtsterkte.	

Tabel "C2" Wijzigen of uitsluiten het niveau van inwerkingtredeing van "zon" (Afb. 9)	Voorbeeld
1. Druk twee keer op het knopje en laat het weer los. Bij het loslaten gaat de Led branden en blijft met GROEN licht branden, ten teken dat ze in de ZON programmeerfase zijn.	     
2. Wacht tot u een Beeptoon hoort	 
3. Druk binnen 4 seconden 1 tot 7 keer op het knopje, afhankelijk van gekozen niveau (zie Tabel B2).	 X1 = 2 KLux X2 = 5 KLux X3 = 10 KLux X4 = 20 KLux X5 = 40 KLux X6 = Auto X7 = Uitsluiting
4. Na enkele ogenblikken hoort u een aantal Beep-tonen begeleid door GROEN knipperlichten, evenveel keren als het ingestelde ZON niveau. De Led blijft vervolgens met GROEN licht branden.	X1 = 2 KLux X2 = 5 KLux X3 = 10 KLux   X4 = 20 KLux X5 = 40 KLux X6 = Auto X7 = Uitsluiting
5. Druk binnen 4 seconden 1 keer op het knopje ter bevestiging. U hoort drie lange Beep-tonen en de Led gaat uit.	 
Opmerking 1 Indien er om welke reden ook een fout begaan wordt in de programmering, hoort u na enkele ogenblikken een reeks korte Beep-tonen en knipperlichten	      
Opmerking 2 Aan het einde van de programmering worden de ingestelde niveaus aangegeven met lichtsignalen, met ROOD licht dat evenveel keren knippert als het ingestelde WIND niveau is, met GROEN licht voor de ingestelde ZONlichtsterkte. (7 maal knipperen wijst op uitsluiting)	

6) Wat u moet doen indien...

Ook al laat u de anemometer sneller laat draaien dan geprogrammeerd is, voeren de motoren de opdracht "Omhoog"(▲) niet uit.

Controleer de spanning bij de sensor verbindingklemmen, die gelijk moet zijn aan de nominale waarde nominale. Indien een andere waarde gemeten wordt, moet u nagaan of de motor in werking is. Verifieer of de sensorcode opgeslagen is in elke motor of regeleenheid die men daarmee wil besturen.

De aansluitingen zijn goed en er wordt een normale elektriciteitsspanning gemeten, maar wanneer u de anemometer laat draaien wordt de omhoogmanoeuvre (▲) niet uitgevoerd.

Het inwerkingtredingsniveau van de WIND beveiliging moet gedurende tenminste 3 seconden overschreden zijn. Laat de anemometer op een geschikte snelheid draaien, probeer eventueel het inwerkingtredingsniveau van de WIND sensor te verlagen, verifieer het met ROOD licht knipperen van de led ten teken dat de opdracht verzonden is.

De werkingscontrole van de WIND sensor is met goed resultaat afgesloten, maar die van de inwerkingtreden van de ZONsensor niet.

De omlaagmanoeuvre van de ZONsensor wordt maar 1 keer bestuurd, terwijl het ingestelde niveau tenminste 2 minuten lang overschreden is. Probeer de motor en sensor uit- en weer aan te zetten en herhaal de test door eventueel het inwerkingtredingsniveau van de ZONsensor. Verifieer het met GROEN knipperen van de led ten teken dat de opdracht verzonden is.

De sensor werkt wel, maar heeft geen radiobereik.

Controleer of er geen andere inrichtingen, zoals alarminrichtingen, radiokoptelefoons enz.... op dezelfde frequentie en met ononderbroken zendingen zijn, die het bereik kunnen verminderen.

7) Technische kenmerken

Algemene kenmerken

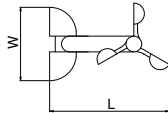
Gevoed door elektriciteitsnet	SKIROSOL SRCK 610	230 Vac 50/60 Hz 1.5W
	SKIROSOL SRCK 610/V1	120 Vac 50/60 Hz 1.5W
Zendfrequentie	433.92 MHz	LDP met ingebouwde antenne
Straalvermogen	Ongeveer 1 mW (e.r.p.)	Komt in optimale omstandigheden overeen met een bereik van ongeveer 100-200 m
IP bescherming	IP 44	
Gebruikstemperatuur	-20 °C ÷ +55 °C	
Houder	Afmetingen	
	W = 120 mm L = 215 mm H = 85 mm	
	Gewicht	P = 250 g

Kenmerken sensoren

Anemometer	Bereik	0-127 Km/h
	Resolutie	1 Km/h
	Conversieconstante	0.26 $\frac{\text{Omwentelingen / s}}{\text{Km / h}}$
	Precisie	± 2 % F.S.
	Programmeerbare niveaus	Niv 1 = 5 Km/h Niv 2 = 10 Km/h Niv 3 = 15 Km/h Niv 4 = 30 Km/h Niv 5 = 45 Km/h
Luxmeter	Bereik	0 ÷ 64 KLux
	Resolutie (KLux)	0 - 10 KLux: 0.25 KLux 10 - 40 KLux: 0.5 KLux 40 - 64 KLux: 1 KLux
	Precisie	± 10% F.S.
	Programmeerbare niveaus	Niv 1 = 2 KLux Niv 2 = 5 KLux Niv 3 = 10 KLux Niv 4 = 20 KLux Niv 5 = 40 KLux Niv 6 = AUTO Niv 7 = Uitsluiting

Wijzigingen voorbehouden zonder voorafgaande kennisgeving.

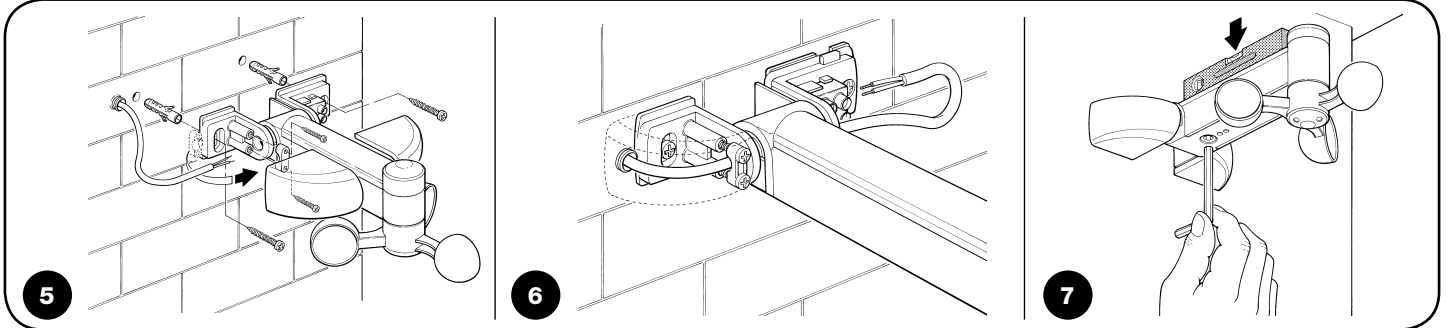
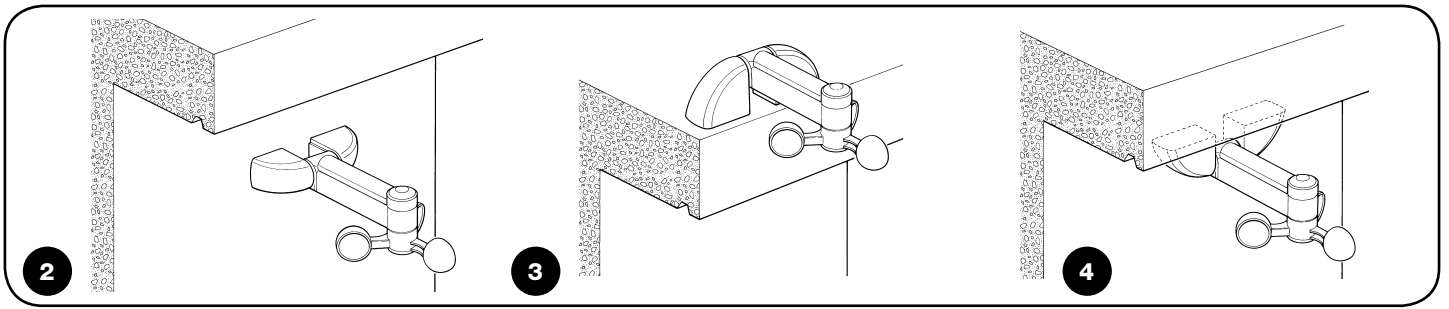

X1

♪ ⊗ ... ♪ ⊗

X1= 5 Km/h
X2= 10 Km/h
X3= 15 Km/h
X4= 30 Km/h
X5= 45 Km/h

♪ ⊗ ♪ ♪ ♪
 ♪ ⊗ ♪ ⊗ ♪ ♪ ♪ ♪ ♪ ⊗
 ♪ ♪ ♪ ♪ ♪ ♪ ♪ ⊗
 ♪ ♪ ♪ ♪ ♪ ♪ ♪ ♪ ♪ ⊗

X1

X2

♪ ⊗ ♪ ⊗ ... ♪ ⊗

X1= 2 KLux
X2= 5 KLux
X3= 10 KLux
X4= 20 KLux
X5= 40 KLux
X6= Auto
X7= Delete

♪ ⊗ ♪ ♪ ♪
 ♪ ⊗ ♪ ⊗ ♪ ♪ ♪ ♪ ♪ ⊗
 ♪ ♪ ♪ ♪ ♪ ♪ ♪ ♪ ♪ ⊗
 ♪ ♪ ♪ ♪ ♪ ♪ ♪ ♪ ♪ ♪ ♪ ⊗
 ♪ ♪ ♪ ♪ ♪ ♪ ♪ ♪ ♪ ♪ ♪ ♪ ♪ ⊗

X1

Hiermit erklären wir, dass dieses Gerät den grundlegenden Anforderungen und relevanten Vorschriften der CE-Richtlinien entspricht.
 Konformitätserklärung: www.stobag.com

Nous déclarons par la présente que cet appareil répond aux exigences fondamentales et aux prescriptions correspondantes des directives CE.
 Déclaration de conformité : www.stobag.com

Con la presente, si dichiara che il dispositivo in oggetto ottempera ai requisiti fondamentali e alle normative pertinenti delle direttive CE.
 Dichiarazione di conformità: www.stobag.com

We hereby declare that this device conforms to the fundamental requirements and relevant provisions of the CE directives.
 Declaration of conformity: www.stobag.com

Por la presente declaramos que este aparato cumple con los requisitos básicos y la normativa relevante de las Directivas CE.
 Declaración de conformidad: www.stobag.com

Hiermee verklaren wij dat dit product aan de voorschriften van de CE norm voldoet.
 Conformiteitverklaring: www.stobag.com

STOBAG AG

STOBAG International
Pilatusring 1
CH-5630 Muri

Phone +41 (0)56 675 48 00
Fax +41 (0)56 675 48 01
export@stobag.com
www.stobag.com

STOBAG AG

STOBAG Schweiz
Pilatusring 1
CH-5630 Muri

Tel. +41 (0)56 675 42 00
Fax +41 (0)56 675 42 01
info@stobag.ch
www.stobag.ch

STOBAG SA

STOBAG Suisse
en Budron H/18
CH-1052 Le Mont-sur-Lausanne

Tél. +41 (0)21 651 42 90
Fax +41 (0)21 651 42 99
suisse-romande@stobag.ch
www.stobag.ch

STOBAG Österreich GmbH

Radlberger Hauptstrasse 100
A-3105 St. Pölten-Unterradlberg

Tel. +43 (0)2742 362 080
Fax +43 (0)2742 362 074
info@stobag.at
www.stobag.at

STOBAG Italia S.r.l.

Via Marconi n. 2/B
I-37010 Affi (VR)

Tel. +39 045 620 00 66
Fax +39 045 620 00 82
info@stobag.it
www.stobag.it

STOBAG Iberia S.L.

Pol. Ind. de Balsicas
C/Laguna de Villasinda nº 21, 23, 25
ES-30591 Balsicas - Murcia

Tel. +34 902 10 64 57
Fax +34 968 58 05 00
info@stobag.es
www.stobag.es

STOBAG Benelux B.V.

Flevolaan 7, 1382 JX Weesp
Postbus 5253, 1380 GG Weesp
Nederland

Tel. +31 (0)294 430 361
Fax +31 (0)294 430 678
info@stobag.nl
www.stobag.nl

STOBAG do Brasil Ltda.

Rua Rafael Puchetti, 1.110
BR-83020-330 São José dos Pinhais - PR

Tel. +55 41 2105 9000
Fax +55 41 2105 9001
stobag@stobag.com.br
www.stobag.com.br

STOBAG North America Corp.

7401 Pacific Circle
Mississauga, Ontario L5T 2A4, Canada

Phone +1 905 564 6111
Fax +1 905 564 3512
northamerica@stobag.com
www.stobag.com

Your local STOBAG Business Partner:

www.stobag.com