

TTD0110

CE

**Wireless receiver for 1-10V
dimmable electronic power**



EN - Instructions and warnings for installation and use

IT - Istruzioni ed avvertenze per l'installazione e l'uso

FR - Instructions et avertissements pour l'installation et l'utilisation

ES - Instrucciones y advertencias para la instalación y el uso

DE - Installierungs-und Gebrauchsanleitungen und Hinweise

PL - Instrukcje i ostrzeżenia do instalacji i użytkowania

NL - Aanwijzingen en aanbevelingen voor installatie en gebruik

Nice

CONTENTS

1	GENERAL WARNINGS	1
2	PRODUCT DESCRIPTION AND INTENDED USE	2
3	ELECTRICAL CONNECTIONS	2
4	PROGRAMMING	4
4.1	“Slider” Function	5
4.2	LED	5
4.3	Transmitter recognition procedure	6
4.3.1	Using the “First Transmitter” (Empty Memory)	6
4.3.2	Using “Further Transmitters” Mode 1	7
4.3.3	Using “Further Transmitters” Mode 2	7
4.3.4	Using the “External Button” Mode 2	8
4.4	Memory deletion	9
4.4.1	Using the “Memorised Transmitter”	9
4.4.2	Using the “External Button”	9
4.5	Programming the brightness levels	10
4.5.1	Using the “Memorised Transmitter”	10
4.5.2	Using the “External Button”	11
4.6	Programming the locking and unlocking of the memory	11
4.6.1	Using the “Memorised Transmitter”	11
4.6.2	Using the “External Button”	12
5	Replacing a fuse	13
6	TECHNICAL SPECIFICATIONS	13
7	DISPOSAL OF THE PRODUCT	13
	EC declaration of conformity	14

1 - GENERAL WARNINGS

- **WARNING: Important safety instructions. Follow all instructions as improper installation may cause serious damage.**
- **ATTENTION: Important safety instructions. It is important for you to comply with these instructions for your own and other people's safety. Keep these instructions.**
- Children must not play with the appliance.
- Do not allow children to play with the fixed control devices of the product. Keep the remote controls away from children.
- Check the system frequently, especially check the wires for signs of wear or damage. Do not use the device if it needs repair or adjustment, because an installation failure can cause injury.
- Cleaning and maintenance that should be carried out by the user must not be carried out by unsupervised children.
- **ATTENTION:** in order to avoid any danger due to inadvertent resetting of the thermal cut-off device, this appliance must not be powered through an external switching device, such as a timer, or connected to a supply that is regularly powered or switched off by the circuit.
- Before starting installation, check the “Product specifications” (in this manual). If it is not suitable, DO NOT continue with the installation.
- The packing materials of the product must be disposed of in compliance with local regulations.
- Before proceeding with the installation of the product, check that all the materials are in good working order and suited to the intended applications.
- The manufacturer assumes no liability for damage to property, items or persons resulting from non-compliance with the assembly instructions. In such cases the warranty for material defects is excluded.
- Before working on the system (maintenance, cleaning), always disconnect the product from the mains power supply.
- Provide a disconnection device (not supplied) in the plant's power supply grid, with a contact opening distance that permits complete disconnection under the conditions dictated by overvoltage category III.
- Handle the product with care during installation, taking care to avoid crushing, denting or dropping it, or allowing contact with liquids of any kind. Keep the product away from sources of heat and naked flames. Failure to observe the above can damage the product, and

increase the risk of danger or malfunction. If this were to happen, stop installation immediately and contact Customer Service.

2 - PRODUCT DESCRIPTION AND INTENDED USE

TTD0110 is a 1-10 Volt voltage regulator which drives the power output of power supply units, with dimmer output, for lamps. **Any other use is improper and prohibited.**

It is equipped with a radio receiver operating at a frequency of 433.92 MHz with “rolling code” encoding.

It can be controlled with Nice compatible products (**Table 1**) and with an external push button to switch on and off and adjust the light intensity of the lamp.

TABLE 1				
Series	Model	Buttons	Programming	Function
Nice Era	Era P	▲	Mode 1 (section 4)	Slider (section 4)
		■		
	Era W	▼		
	Era MiniWay			
	Era One	○	Mode 2 (section 4)	
	Era Inti			
NiceWay	NiceWay	▲	Mode 1 (section 4)	
Nice Ergo	Ergo	■		
		▼		
Nice Flor	Flor-m	○	Mode 2 (section 4)	
Nice Very	Very VR	▲	Mode 1 (section 4)	
		■		
		▼		
Nice Home	Touch HSTS2	display	Mode 1 (section 4)	
	HSTX8	○	Mode 2 (section 4)	

3 - ELECTRICAL CONNECTIONS

Special warnings:

- **The product is subjected to hazardous voltage: therefore, only open the housing and make connections with the power switched off.**
- **Never cut the antenna cable, because it is subject to hazardous voltage.**

In order to make the electrical connections, you need to open the TTD0110 (**Fig. 1**) and then proceed as shown in **Fig. 2** and **3** (complete example of electrical connection):

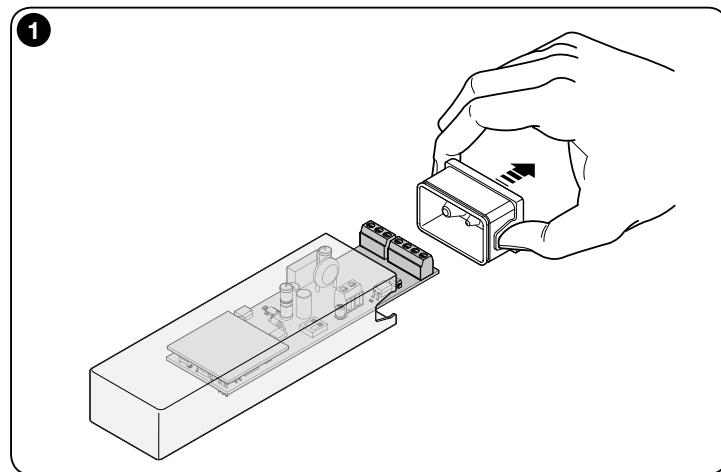

2

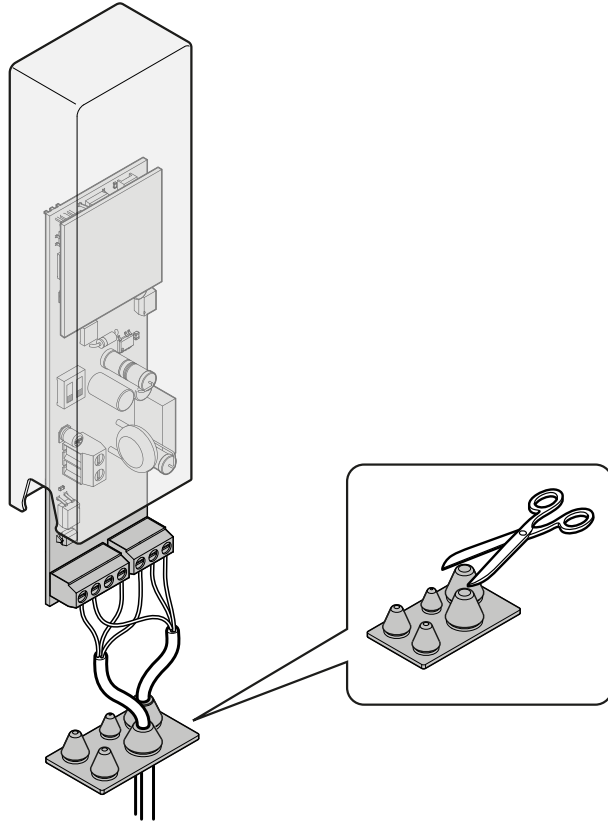

3

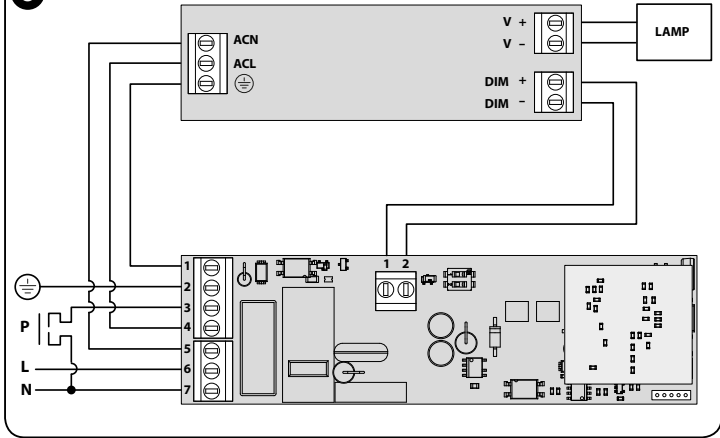

	supply voltage	terminals
TTD0110 Input/Power supply	220 - 240 Vac	7 - phase N 6 - neutral F 2 - earth T
External driver output/power supply		5 - phase N 4 - neutral F 1 - earth T
Output/External button		3 - button P 7 - neutral N
	low voltage	terminals
Output/External driver: adjustment 1-10 V or 0-10 V or 2-10 V or PWM	dimmer connected to power supply/driver	1 (-) 2 (+)

The product has two dip-switches (**Fig. 4**) that allow you to select the type of load that will be connected to the output:

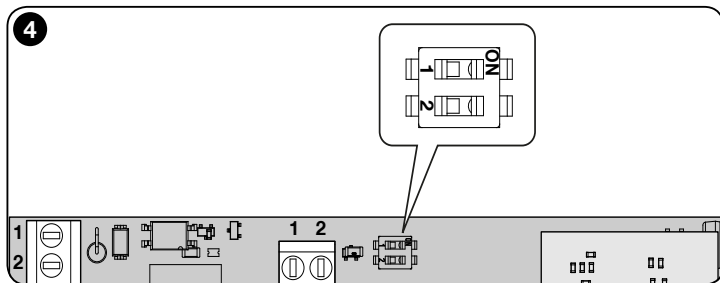



Dip 1	Dip 2	Description
Off	Off	Output 2-10 V
On	Off	Output 1-10 V
Off	On	Output 0-10 V
On	On	PWM (1k Hz)

Note: check the type of load in the technical specifications of the device that is to be connected

4 - PROGRAMMING

The TTD0110 must be programmed with a transmitter memorised in “Mode 1” or with the external button.

Up to 30 transmitters can be memorised in “**Mode 1**” or in “**Mode 2**” in order to get different behaviours:

TABLE 2	
Mode 1: automatically assign the three commands to the first three buttons on the transmitter	
Buttons	Function
 / ①	Dimmer up
 / ②	Toggle

 / ③	Dimmer down
④ ...	-

Mode 2: freely associate one command from among those available

Function	Procedure	Description
Dimmer up	1 short press on the button (< 1 second)	the brightness of the lamp increases by a small percentage if it is not already set to the maximum value
	1 long press on the button (> 1 second)	the brightness of the lamp increases until it reaches the maximum value set or until the button is released
Toggle	every time you press the button	the dimmer turns the lamp On or Off. Brightness associated with “On”: the last brightness value set on the dimmer. This value is memorised automatically by the dimmer when the lamp is switched off (i.e. the memorised value will be the brightness of the lamp before being switched off) or, in any case, about 60 seconds since the brightness was last adjusted (i.e. the last brightness value).
Dimmer down	1 short press on the button (< 1 second)	the brightness of the lamp decreases by a small percentage if it is not already set to the minimum value
	1 long press on the button (> 1 second)	the brightness of the lamp decreases until it reaches the minimum value set or until the button is released
Dimmer up Toggle Dimmer down ...	every time you press the button	the various functions are performed alternately

4.1 - "Slider" Function

This allows you to turn the lamps On and Off and to adjust the brightness dynamically. The capacitive strip acts like a slider:

Procedure	Description
short touch on the slider	absolute positioning command
sliding your finger on the slider	progression of commands to adjust the brightness dynamically: sending commands regardless of where you place your finger

4.2 - LED (Fig. 5)

The LED on the lower part of the TTD01 10 sends various signals in the programming procedures and some general signals:















Flashes	Colour	Execution	Description
6	green	at the end of a transmitter memorisation procedure	the memory is full: the transmitter cannot be memorised
2	green	when the dimmer is powered	its memory is empty (= no transmitter memorised)
2	red	during any programming procedure	an error was committed
on fixed	blue	it comes on when the power supply unit / driver is activated	voltage to terminals 5 and 4



5

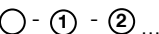

In this manual the programming procedures are explained with the use of icons and their meanings are shown in the table below:

KEY	
LED: behaviour during the programming procedures	
Symbol	Description
	ON
	OFF
	LONG flashing
	SHORT flashing
	FAST flashing
other symbols	
Symbol	Description
	DISCONNECT POWER









	CONNECT POWER
	LAMP ON
	LAMP OFF
	DESIRED VALUE FOR THE BRIGHTNESS OF THE LAMP
	PRESS BRIEFLY
	PRESS AND HOLD THE BUTTON ON THE TRANSMITTER
	RELEASE THE BUTTON ON THE TRANSMITTER
	PRESS AND HOLD THE BUTTON ON THE TRANSMITTER AT THE SAME TIME
	RELEASE THE BUTTON ON THE TRANSMITTER AT THE SAME TIME
	TRANSMITTER BUTTONS
	TRANSMITTER BUTTONS
	BRIEFLY PRESS THE DESIRED BUTTON ON THE TRANSMITTER
	VIEW/SELECT
	WAIT FOR...
	WAIT FOR A PRECISE TIME

	BRIEFLY PRESS THE EXTERNAL BUTTON
	PRESS AND HOLD THE EXTERNAL BUTTON
	RELEASE THE EXTERNAL BUTTON

4.3 - Transmitter recognition procedure









4.3.1 - Using the "First Transmitter" (Empty Memory)

This procedure allows you to associate a transmitter to the dimmer in "Mode 1".

01.		 2 seconds		2  Green LED
02.	within 5 seconds	  for 8 seconds		
03.	2  green LED: memorising OK			
	2  red LED: memorising NOT CONCLUDED <i>in this case, repeat the procedure from the beginning</i>			



4.3.2 - Using “Further Transmitters”: Mode 1













This procedure allows you to associate a transmitter to the dimmer in “Mode 1”.









01.	NEW transmitter	 for 8 seconds		1  red LED
02.	OLD transmitter already memorised		x 3 	
03.	NEW transmitter	 for 5 seconds		
04.	2  green LED: memorising OK			
	2  red LED: memorising NOT CONCLUDED <i>in this case, repeat the procedure from the beginning</i>			

4.3.3 - Using “Further Transmitters”: Mode 2

This procedure allows you to associate a transmitter to the dimmer in “Mode 2”.











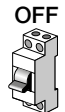





01.	OLD transmitter already memorised	 for 8 seconds		1  green LED
------------	--	--	---	--

















02.	OLD transmitter already memorised	 for 8 seconds		2  green LED
03.	OLD transmitter already memorised	 select the desired function:		
	Dimmer Up > Toggle > Dimmer Down			x 1 
	Dimmer Up			x 2 
	Dimmer Down			x 3 
	Toggle			x 4 
	Level 1			x 5 
	Level 2			x 6 
	Level 3			x 7 
	Level 4			x 8 
	OFF			x 9 

	ON		x 10 
04.	 5 seconds = 	...  green LED no. of ... flashes according to the chosen function	
05.	 desire button on the transmitter	green LED 	 3 sec. = 
06.	2  green LED: memorising OK		

4.3.4 - Using "External Button": Mode 2

This procedure allows you to associate a transmitter to the dimmer in "Mode 2".

01.	 OFF		 ON		 green LED	 3 sec. = 	
02.		green LED 	 3 sec. = 		at the 5th 		
03.	 select the desired function						
	Dimmer Up > Toggle > Dimmer Down					x 1 	

	Dimmer Up	x 2 		
	Dimmer Down	x 3 		
	Toggle	x 4 		
	Level 1	x 5 		
	Level 2	x 6 		
	Level 3	x 7 		
	Level 4	x 8 		
	OFF	x 9 		
	ON	x 10 		
04.	 5 seconds	 green LED no. of ... flashes according to the chosen function		
05.	 desire button on the transmitter	green LED 	 3 sec. = 	
06.	2  green LED: memorising OK			

4.4 - Memory deletion

4.4.1 - Using “Memorised Transmitter”:

By using a transmitter memorised in “Mode 1”, you can fully or partially delete the memory.

01.			1 green LED	
02.			2 green LED	
03.			3 green LED	
04.			4 green LED	
05.	select the desired function			
	Delete only the transmitters			
	Delete only the parameters			

	Delete only the transmitters and parameters		
06.	5 seconds	2 green LED	
	2 red LED: memorising NOT CONCLUDED <i>in this case, repeat the procedure from the beginning</i>		

4.4.2 - Using “External Button”:

01.							3 sec. =	
02.				3 sec. =		at the 2nd		
03.				3 sec. =		at the 5th		
04.	select the desired function							

	Delete only the transmitters		x 1	
	Delete only the parameters		x 2	
	Delete only the transmitters and parameters		x 3	
05.	5 seconds	green LED no. of ... flashes according to the chosen function		
06.		green LED	3 sec. =	
07.	2 green LED: memorising OK			

4.5 - Programming the brightness levels

4.5.1 - Using "Memorised Transmitter":





















This procedure can only be done using a transmitter already memorised in "Mode 1".













The memorised brightness level can only be recalled after being associated with a transmitter button programmed in Mode 2.

01.		3 sec.	1 green LED	
-----	--	--------	--------------	--

02.		3 sec.	2 green LED	
03.	Use the keys ▲ - ▼ to adjust brightness	desired light intensity value	10 seconds	2 green LED
04.	select the desired function			
	Level 1		=	2 green LED
	Level 2		=	2 green LED
	Level 3		=	2 green LED
	Level 4		=	2 green LED

4.5.2 - Using “External Button”:





01.					green LED		3 sec. = ■	
02.			green LED		3 sec. = ■			
03.			green LED		3 sec. = ■		at the 2nd	
04.	Adjusting the brightness of the lamp to the desired value using the external push button:							
	1st long press on the external button = increase in brightness until you release the button							
	2nd long press on the external button = decrease in brightness until you release the button							
	CAUTION!  = “Toggle” function (ON/OFF)							
05.		desired light intensity value		5 seconds	= 2		+	

06.		select the desired level	
	Level 1	x 1	
	Level 2	x 2	
	Level 3	x 3	
	Level 4	x 4	
07.		5 seconds	 green LED +  no. of ... flashes according to the chosen level
08.			green LED
			3 sec. = ■
09.	2		green LED: memorising OK

4.6 - Programming the locking and unlocking of the memory

4.6.1 - Using “Memorised Transmitter”:

This procedure can only be done using a transmitter already memorised in “Mode 1”.

01.			1		green LED	
-----	--	--	----------	--	------------------	--

02.			2 green LED	
03.			3 green LED	
04.			4 green LED	
05.	select the desired function			
	To lock the memory		2 ; ■	
	To Unlock the memory		2 ; ■	

4.6.2 - Using "External Button":

01.	OFF 		ON 		green LED	3 sec. = ■	
-----	---------	--	--------	--	-----------	------------	--

02.		green LED		3 sec. = ■		at the 2nd
03.		green LED		3 sec.= ■		at the 2nd
04.	select the desired function					
	To lock the memory					x 1
	To unlock the memory					x 2
05.		5 seconds	green LED + no. of ... flashes according to the chosen function			
06.		green LED		3 sec. = ■		
07.	2 green LED: memorising OK					

5 - Replacing a fuse

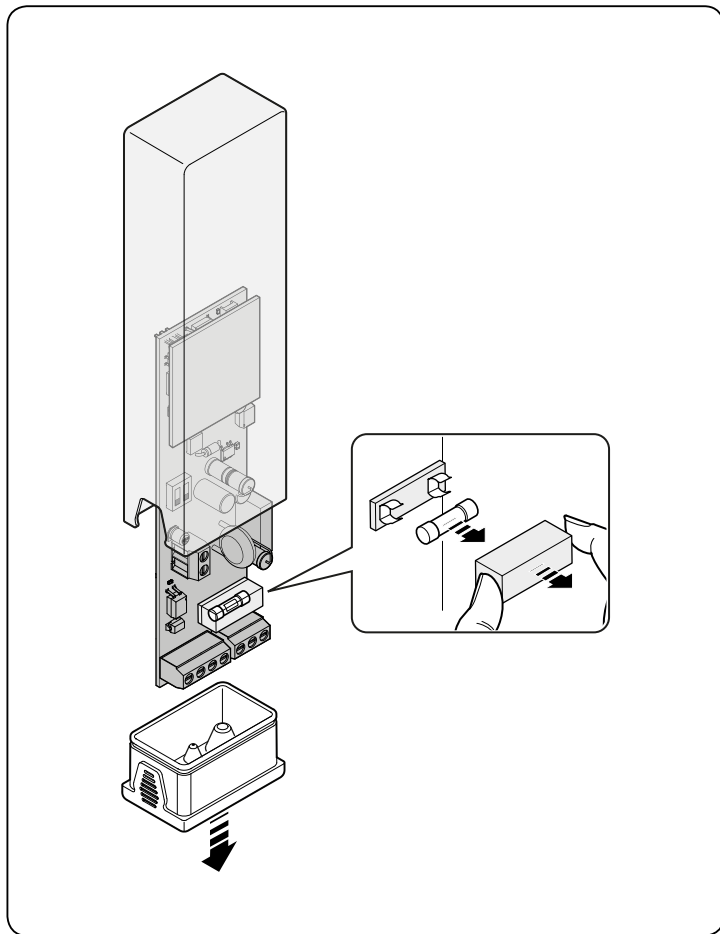

6 - TECHNICAL SPECIFICATIONS

Input	
Voltage	230 Vac \pm 10%
Frequency	50 Hz
Power consumption (standby)	550 mW
Output	
Voltage	230 Vac \pm 10%
Frequency	50 Hz
Maximum start-up current	80 A
Environment	
Operating temperature	-40 + 55° C
Storage temperature	-40 + 70° C
IP	54
Dimensions	43 x 25 x 150 mm
Weight	100 g

7 - SCRAPPING THE PRODUCT

As in installation, also at the end of product lifetime, the disassembly and scrapping operations must be performed by qualified personnel. This product is made up of different types of material, some of which can be recycled while others must be disposed of. Seek information on the recycling and disposal systems envisaged by the local regulations in your area for this product category.

Caution! – some parts of the product may contain pollutant or hazardous substances which, if disposed of into the environment, may cause serious damage to the environment or physical health.



As indicated by the symbol on the left, disposal of this product in domestic waste is strictly prohibited. Separate the waste into categories for disposal, according to the methods envisaged by current legislation in your area, or return the product to the retailer when purchasing a new version.

Caution! – Local legislation may envisage serious fines in the event of abusive disposal of this product. The packing materials of the product must be disposed of in compliance with local regulations.

EC DECLARATION OF CONFORMITY

Declaration in compliance with Directive 1999/5/EC

Note – The content of this declaration corresponds to that specified in the official document deposited at the Nice S.p.a. headquarters and, in particular, to the latest revised edition available prior to the publishing of this manual. The text herein has been re-edited for editorial purposes. A copy of the original declaration can be requested from Nice S.p.A. (TV) I.

Declaration number: **520/TTD0110** Revision: **0** Language: **EN**

The undersigned, Mauro Sordini, CEO, declares under his sole responsibility that the following product: • **Manufacturer's name:** NICE S.p.A. • **Address:** Via Pezza Alta No. 13, 31046 Rustignè di Oderzo (TV) Italy • **Type of product:** 1-10 V Radio receiver for dimmable electronic power units • **Model / Type:** TTD0110 • **Accessories:** -

Complies with the essential requirements pursuant to Article 3 of the following European directive, relevant to the use for which the products are intended:

- DIRECTIVE 1999/5/EC OF THE EUROPEAN PARLIAMENT AND OF THE COUNCIL of 9 March 1999 on radio equipment and telecommunications terminal equipment and the mutual recognition of their conformity, in accordance with the following harmonised standards:
 - Health and safety (Art. 3(1)(a)): EN 62479:2010
 - Electrical safety (Art. 3(1)(a)): EN 60950-1:2006+A1:2010+A12:2011+A11:2009+A2:2013
 - Electromagnetic compatibility (Art. 3(1)(b)): EN 301 489-1 V1.9.2:2011, EN 301 489-3 V1.6.1:2013
 - Radio spectrum (Art. 3(2)): EN 300 220-2 V2.4.1:2012

Moreover, the product complies with that specified in the following European directives:

Directive 2006/95/EC of the European Parliament and Council dated 12 December 2006 on the harmonisation of the laws of Member states relating to electrical equipment designed for use within certain voltage limits, according to the following harmonised regulations:

- EN 60669-2-1:2004+A1:2009+A12:2010
- DIRECTIVE 2004/108/EC OF THE EUROPEAN PARLIAMENT AND COUNCIL of 15 December 2004 on the approximation of the laws of Member States relating to electromagnetic compatibility and repealing Directive 89/336/EEC, in accordance with the following harmonised standards:
 - EN 55015:2006+A1:2007+A2:2009, EN 61547:2009, EN 61000-3-2:2006+A1:2009+A2 :2009, EN 61000-3-3:2013

Oderzo, 09 December 2014

Mr. Mauro Sordini (Chief Executive Officer)



SOMMARIO

1	AWVERTENZE GENERALI	1
2	DESCRIZIONE DEL PRODOTTO E DESTINAZIONE D'USO	2
3	COLLEGAMENTI ELETTRICI	2
4	PROGRAMMAZIONE	4
4.1	Funzione "Slider"	5
4.2	LED	5
4.3	Procedura di apprendimento Trasmettitori	6
4.3.1	Utilizzo "Primo Trasmettitore" (Memoria Vuota)	6
4.3.2	Utilizzo "Ulteriori Trasmettitori": Modo 1	7
4.3.3	Utilizzo "Ulteriori Trasmettitori": Modo 2	7
4.3.4	Utilizzo "Pulsante Esterno": Modo 2	8
4.4	Cancellazione della Memoria	9
4.4.1	Utilizzo "Trasmettitore memorizzato"	9
4.4.2	Utilizzo "Pulsante Esterno"	9
4.5	Programmazione livelli di luminosità	10
4.5.1	Utilizzo "Trasmettitore memorizzato"	10
4.5.2	Utilizzo "Pulsante Esterno"	11
4.6	Programmazione blocco e sblocco della memoria	11
4.6.1	Utilizzo "Trasmettitore memorizzato"	11
4.6.2	Utilizzo "Pulsante Esterno"	12
5	Sostituzione fusibile	13
6	CARATTERISTICHE TECNICHE	13
7	SMALTIMENTO DEL PRODOTTO	13
	Dichiarazione CE di conformità	14

1 - AVVERTENZE GENERALI

- **AVVERTENZA: Istruzioni importanti per la sicurezza. Seguire tutte le istruzioni poiché l'installazione non corretta può causare gravi danni.**
- **ATTENZIONE: Importanti istruzioni di sicurezza. Per la sicurezza delle persone è importante seguire queste istruzioni. Conservare queste istruzioni.**
- I bambini non devono giocare con l'apparecchio.
- Non permettere ai bambini di giocare con i dispositivi di comando del prodotto. Tenere i telecomandi lontano dai bambini.
- Verificare frequentemente l'impianto, in particolare controllare i cavi, segni di usura o danni. Non usare se è necessaria una riparazione o una regolazione, poiché un guasto all'installazione può provocare lesioni.
- La pulizia e la manutenzione destinata ad essere effettuata dall'utilizzatore non deve essere effettuata da bambini senza sorveglianza.
- **ATTENZIONE:** al fine di evitare ogni pericolo dovuto al riarmo accidentale del dispositivo termico di interruzione, questo apparecchio non deve essere alimentato con un dispositivo di manovra esterno, quale un temporizzatore, oppure essere connesso a un circuito che viene regolarmente alimentato o disalimentato dal servizio.
- Prima di iniziare l'installazione verificare le "Caratteristiche tecniche del prodotto" (in questo manuale). Se non è adatto, **NON** procedere all'installazione.
- Il materiale dell'imballo del prodotto deve essere smaltito nel pieno rispetto della normativa locale.
- Prima di procedere con l'installazione del prodotto, verificare che tutto il materiale da utilizzare sia in ottimo stato ed adeguato all'uso.
- Il produttore non si assume alcuna responsabilità per danni patrimoniali, a cose o a persone derivanti dalla non osservanza delle istruzioni di montaggio. In questi casi è esclusa la garanzia per difetti materiali.
- Prima degli interventi sull'impianto (manutenzione, pulizia), disconnettere sempre il prodotto dalla rete di alimentazione.
- Nella rete di alimentazione dell'impianto prevedere un dispositivo di disconnessione (non in dotazione) con una distanza di apertura dei contatti che consenta la disconnessione completa nelle condizioni

dettate dalla categoria di sovratensione III.

- Durante l'installazione maneggiare con cura il prodotto evitando schiacciamenti, urti, cadute o contatto con liquidi di qualsiasi natura. Non mettere il prodotto vicino a fonti di calore, né esporlo a fiamme libere. Tutte queste azioni possono danneggiarlo ed essere causa di malfunzionamenti o situazioni di pericolo. Se questo accade, sospendere immediatamente l'installazione e rivolgersi al Servizio Assistenza.

2 - DESCRIZIONE DEL PRODOTTO E DESTINAZIONE D'USO

TTD0110 è un regolatore di tensione 1-10 Volt che pilota l'uscita di potenza di alimentatori/driver per la regolazione di sorgenti luminose.

Ogni altro uso è improprio e vietato.

È dotato di un ricevitore radio che opera alla frequenza di 433.92 MHz con codifica "rolling code".

Può essere comandato con i prodotti Nice compatibili (**Tabella 1**) e con un pulsante esterno per accendere, spegnere e regolare l'intensità luminosa della lampada.

TABELLA 1

Serie	Modello	Tasti	Programmazione	Funzionalità
Nice Era	Era P	▲	Modo 1 (capitolo 4)	Slider (capitolo 4)
		■		
	Era W	▼		
	Era MiniWay			
	Era One	○	Modo 2 (capitolo 4)	
	Era Inti			
NiceWay	NiceWay	▲	Modo 1 (capitolo 4)	
Nice Ergo	Ergo	■		
		▼		
Nice Flor	Flor-m	○	Modo 2 (capitolo 4)	
Ncice Very	Very VR	▲	Modo 1 (capitolo 4)	
		■		
		▼		

Nice Home	Touch HSTS2	display	Modo 1 (capitolo 4)	
	HSTX8	○	Modo 2 (capitolo 4)	

3 - COLLEGAMENTI ELETTRICI

Avvertenze specifiche:

- Il prodotto è sottoposto a tensione elettrica pericolosa: l'apertura del contenitore e tutti i collegamenti elettrici devono essere eseguiti in assenza di tensione elettrica.
- Non tagliare per nessun motivo il cavo dell'antenna che è sottoposto a tensione elettrica pericolosa.

Per eseguire i collegamenti elettrici è necessario aprire TTD0110 (**fig. 1**) e poi procedere come mostrato in **fig. 2 e 3** (esempio di collegamento elettrico completo):

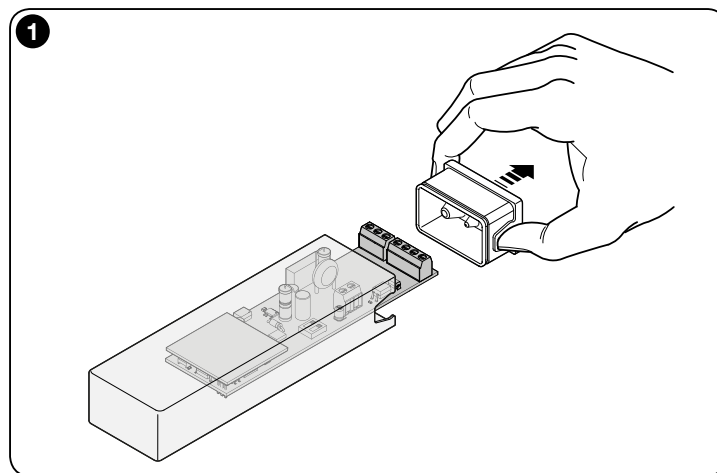

2

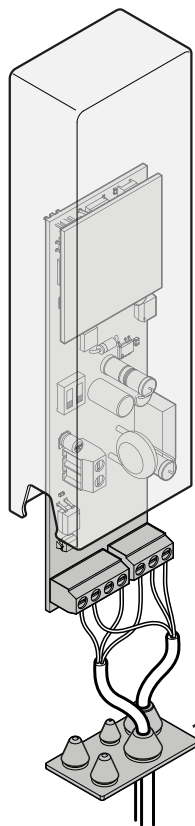

3

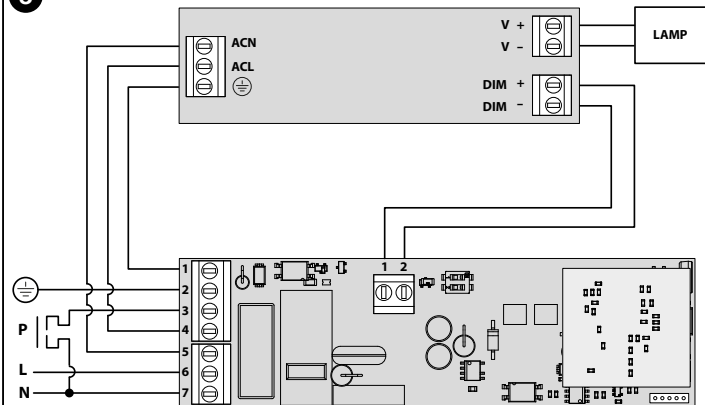

	tensione di rete	morsetti
Ingresso / Alimentazione TTD0110	220 - 240 Vac	7 - fase N 6 - neutro F 2 - terra T
Uscita / Alimentazione Driver esterno		5 - fase N 4 - neutro F 1 - terra T
Uscita / Pulsante esterno		3 - pulsante P 7 - neutro N
	bassa tensione	morsetti
Uscita / Driver esterno: regolazione 1-10 V o 0-10 V o 2-10 V o PWM	dimmer connesso ad alimentatore/driver	1 (-) 2 (+)

Il prodotto presenta due dip-switch (**fig. 4**) che permettono di selezionare il tipo di carico che verrà collegato all'uscita:

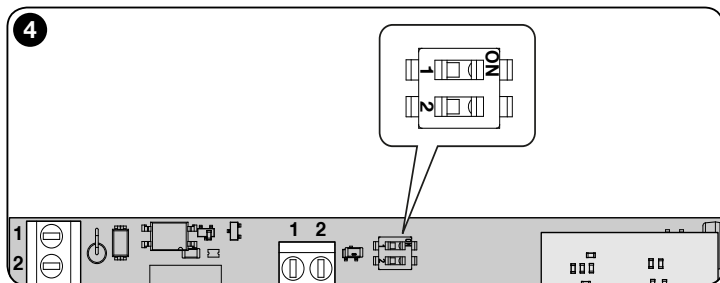

Dip 1	Dip 2	Descrizione
Off	Off	Uscita 2-10 V
On	Off	Uscita 1-10 V
Off	On	Uscita 0-10 V
On	On	PWM (1k Hz)



Nota: verificare la tipologia di carico nelle caratteristiche tecniche del dispositivo che verrà collegato.

4 - PROGRAMMAZIONE

La programmazione di TTD0110 deve essere eseguita con un trasmettitore memorizzato in "Modo 1" o con il pulsante esterno.

Possono essere memorizzati fino a 30 trasmettitori in "**Modo 1**" oppure in "**Modo 2**" per ottenere comportamenti differenti:

TABELLA 2	
Modo 1: assegnare automaticamente i tre comandi ai primi tre tasti del trasmettitore	
Tasti	Funzione
 / ①	Dimmer up

 / ②	Toogle
 / ③	Dimmer down
④ ...	-

Modo 2 : associare liberamente un comando tra quelli disponibili

Funzione	Procedura	Descrizione
Dimmer up	1 pressione breve del tasto (< 1 secondo)	la luminosità della lampada aumenta di una piccola percentuale se non è già impostata sul valore massimo
	1 pressione prolungata del tasto (> 1 secondo)	la luminosità della lampada aumenta fino al raggiungimento del valore massimo impostato o al rilascio del tasto
Toogle	ogni pressione del tasto	il dimmer accende (On) o spegne (Off) la sorgente luminosa collegata. Valore di luminosità associato a "On": ultima soglia di luminosità memorizzata nel dimmer. Il valore viene memorizzato automaticamente dal dimmer quando la lampada da accesa viene spenta (in questo caso il valore memorizzato sarà pari alla luminosità della lampada prima dello spegnimento) o comunque dopo circa 60 secondi dall'ultima variazione di luminosità (in questo caso viene memorizzato l'ultimo valore).
Dimmer down	1 pressione breve del tasto (< 1 secondo)	la luminosità della lampada diminuisce di una piccola percentuale se non è già impostata sul valore minimo

	1 pressione prolungata del tasto (> 1 secondo)	la luminosità della lampada diminuisce fino al raggiungimento del valore minimo impostato o al rilascio del tasto
Dimmer up Toggle Dimmer down ...	ogni pressione del tasto	le varie funzioni vengono eseguite in modo alternato

4.1 - Funzione “Slider”

Consente accensione / spegnimento delle lampade e la regolazione dinamica della luminosità. La superficie capacitiva si comporta come un cursore (slider):

Procedura	Descrizione
tocco breve dello slider	comando di posizionamento assoluto
scorrimento sullo slider	progressione di comandi per regolare la luminosità in modo dinamico: invio di comandi indipendentemente da dove viene posizionato il dito

4.2 - LED (fig. 5)

Il Led presente sulla parte inferiore di TTD0110, esegue varie segnalazioni sia nelle procedure di programmazione sia segnalazioni generiche:

Lampeggi	Colore	Esecuzione	Descrizione
6	verde	al termine di una procedura di memorizzazione di un trasmettitore	la memoria è piena non è possibile memorizzare il trasmettitore
2	verde	quando viene alimentato il dimmer	la sua memoria è vuota (= nessun trasmettitore memorizzato)



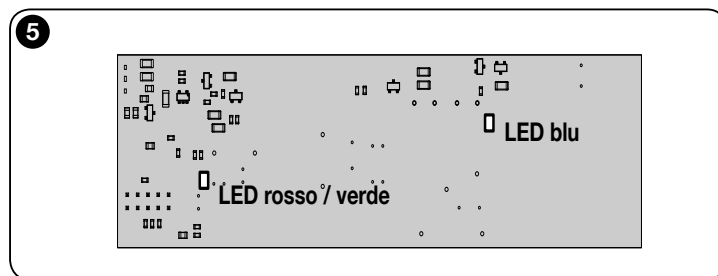



2	rosso	durante una qualsiasi procedura di programmazione	è stato commesso un errore
accesso fisso	blu	si accede quando viene attivato l'alimentatore / driver	Tensione morsetti 5 e 4



In questo manuale le procedure di programmazione sono spiegate con l'uso di icone e il loro significato è riportato nella tabella di seguito:

LEGENDA	
LED: comportamento durante le procedure di programmazione	
Simbolo	Descrizione
	ACCESO
	SPENTO
	lampeggio LUNGO
	lampeggio BREVE
	lampeggio VELOCE









altri simboli	
Simbolo	Descrizione
	TOGLIERE ALIMENTAZIONE
	DARE ALIMENTAZIONE
	LAMPADA ACCESA
	LAMPADA SPENTA
	VALORE DESIDERATO DELLA LUMINOSITA' DELLA LAMPADA
	PREMERE BREVEMENTE
	MANTENERE PREMUTO IL TASTO DEL TRASMETTITORE
	RILASCIARE IL TASTO DEL TRASMETTITORE
	MANTENERE PREMUTO CONTEMPORANEAMENTE IL TASTO DEL TRASMETTITORE
	RILASCIARE CONTEMPORANEAMENTE IL TASTO DEL TRASMETTITORE
	TASTI TRASMETTITORE
	TASTI TRASMETTITORE

	PREMERE BREVEMENTE IL TASTO DESIDERATO DEL TRASMETTITORE
	OSSERVARE / SCEGLIERE
	ATTENDERE CHE ...
	ATTENDERE UN TEMPO PRECISO
	PREMERE BREVEMENTE IL TASTO ESTERNO
	MANTENERE PREMUTO IL TASTO ESTERNO
	RILASCIARE IL TASTO ESTERNO

4.3 - Procedura di apprendimento Trasmettitori









4.3.1 - Utilizzo "Primo Trasmettitore" (Memoria Vuota)

Questa procedura permette di associare al dimmer un trasmettitore in "Modo I".

01.		 2 secondi		2  led verde
02.	entro 5 secondi	  per 8 secondi		
03.	2  led verde: memorizzazione OK			
	2  led rosso: memorizzazione NON CONCLUSA <i>in questo caso ripetere la procedura dall'inizio</i>			



4.3.2 - Utilizzo “Ulteriori Trasmettitori”: Modo 1













Questa procedura permette di associare al dimmer un trasmettitore in “Modo 1”.









01.	NUOVO trasmettitore	 per 8 secondi		1  led rosso
02.	VECCHIO trasmettitore già memorizzato		x 3 	
03.	NUOVO trasmettitore	 per 5 secondi		
04.	2  led verde: memorizzazione OK			
	2  led rosso: memorizzazione NON CONCLUSA <i>in questo caso ripetere la procedura dall’inizio</i>			

4.3.3 - Utilizzo “Ulteriori Trasmettitori”: Modo 2

Questa procedura permette di associare al dimmer un trasmettitore in “Modo 2”.











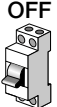





01.	VECCHIO trasmettitore già memorizzato	 per 8 secondi		1  led verde
------------	--	--	---	---

















02.	VECCHIO trasmettitore già memorizzato	 per 8 secondi		2  led verde
03.	VECCHIO trasmettitore già memorizzato	 scegliere la funzione desiderata:		
	Dimmer Up > Toggle > Dimmer Down			x 1 
	Dimmer Up			x 2 
	Dimmer Down			x 3 
	Toggle			x 4 
	Livello 1			x 5 
	Livello 2			x 6 
	Livello 3			x 7 
	Livello 4			x 8 
	OFF			x 9 

	ON	x 10 
04.	 5 secondi = 	...  led verde n°... lampeggi in base alla funzione scelta
05.	 tasto desiderato del trasmettitore	 led verde  3 sec. = 
06.	2  led verde: memorizzazione OK	

4.3.4 - Utilizzo "Pulsante Esterno": Modo 2

Questa procedura permette di associare al dimmer un trasmettitore in "Modo 2".

01.					 led verde	 3 sec. = 	
02.		 led verde	 3 sec. = 			al 5° 	
03.	 scegliere la funzione desiderata						
	Dimmer Up > Toggle > Dimmer Down					x 1 	

	Dimmer Up	x 2 	
	Dimmer Down	x 3 	
	Toggle	x 4 	
	Livello 1	x 5 	
	Livello 2	x 6 	
	Livello 3	x 7 	
	Livello 4	x 8 	
	OFF	x 9 	
	ON	x 10 	
04.	 5 secondi	 led verde n°... lampeggi in base alla funzione scelta	
05.	 tasto desiderato del trasmettitore	 led verde  3 sec. = 	
06.	2  led verde: memorizzazione OK		

4.4 - Cancellazione della Memoria

4.4.1 - Utilizzo “Trasmettitore memorizzato”

Utilizzando un trasmettitore memorizzato in “Modo 1” è possibile eseguire la cancellazione totale o parziale della memoria.

01.			1 led verde	
02.			2 led verde	
03.			3 led verde	
04.			4 led verde	
05.	scegliere la funzione desiderata			
	Cancellare solo i trasmettitori			
	Cancellare solo i parametri			

	Cancellare solo i trasmettitori e i parametri		
06.	5 secondi	2 led verde	
	2 led rosso: memorizzazione NON CONCLUSA in questo caso ripetere la procedura dall'inizio		

4.4.2 - Utilizzo “Pulsante Esterno”

01.						led verde	3 sec. =	
02.		led verde			3 sec. =		al 2°	
03.		led verde			3 sec. =		al 5°	
04.	scegliere la funzione desiderata							

	Cancellare solo i trasmettitori	x 1	
	Cancellare solo i parametri	x 2	
	Cancellare solo i trasmettitori e i parametri	x 3	
05.	5 secondi	led verde n°... lampeggi in base alla funzione scelta	
06.		led verde	3 sec. =
07.	2 led verde: memorizzazione OK		

4.5 - Programmazione livelli di luminosità

4.5.1 - Utilizzo "Trasmettitore memorizzato"





















Questa procedura può essere eseguita solo con un trasmettitore già memorizzato in "Modo 1".













Il livello di luminosità memorizzato sarà richiamabile esclusivamente dopo averlo associato ad un tasto di un trasmettitore programmato in Modo 2.

01.		3 sec.	1 led verde	
------------	--	--------	--------------	--

02.		3 sec.	2 led verde		
03.	Utilizzare i tasti ▲ - ▼ per regolare luminosità	valore intensità di luce desiderato	10 secondi led verde	2	
04.	scegliere la funzione desiderata				
	Livello 1		=	2 led verde	
	Livello 2		=	2 led verde	
	Livello 3		=	2 led verde	
	Livello 4		=	2 led verde	

4.5.2 - Utilizzo “Pulsante Esterno”





01.						
			led verde	3 sec. = ■		
02.						
		led verde	3 sec. = ■			
03.						
		led verde	3 sec. = ■		al 2°	
04.	Regolare la luminosità della lampada al valore desiderato utilizzando il pulsante esterno:					
	1^ pressione prolungata del pulsante esterno = aumento della luminosità fino al rilascio del pulsante					
	2^ pressione prolungata del pulsante esterno = diminuzione della luminosità fino al rilascio del pulsante					
	ATTENZIONE!  = funzione “Toggle” (ON/OFF)					
05.			= 2			
	valore intensità di luce desiderato	5 secondi				

06.		scegliere il livello desiderato				
	Livello 1	x 1				
	Livello 2	x 2				
	Livello 3	x 3				
	Livello 4	x 4				
07.		5 secondi		led verde +		n° ... lampeggi in base al livello scelto
08.			led verde		3 sec. = ■	
09.	2		led verde: memorizzazione OK			

4.6 - Programmazione blocco e sblocco della memoria

4.6.1 - Utilizzo “Trasmettitore memorizzato”

Questa procedura può essere eseguita solo con un trasmettitore già memorizzato in “Modo 1”.

01.			1		led verde	
-----	--	--	----------	--	------------------	--

02.			2 led verde	
03.			3 led verde	
04.			4 led verde	
05.	scegliere la funzione desiderata			
	Bloccare memoria		2 ; ■	
	Sbloccare memoria		2 ; ■	

4.6.2 - Utilizzo "Pulsante Esterno"

01.							led verde 3 sec. = ■
02.		led verde		3 sec. = ■			al 2°
03.		led verde		3 sec. = ■			al 2°
04.	scegliere la funzione desiderata						
	Bolccare memoria						x 1
	Sbloccare memoria						x 2
05.	5 secondi			led verde + n°... lampeggi in base alla funzione scelta			
06.		led verde		3 sec. = ■			
07.	2 led verde: memorizzazione OK						

5 - Sostituzione fusibile

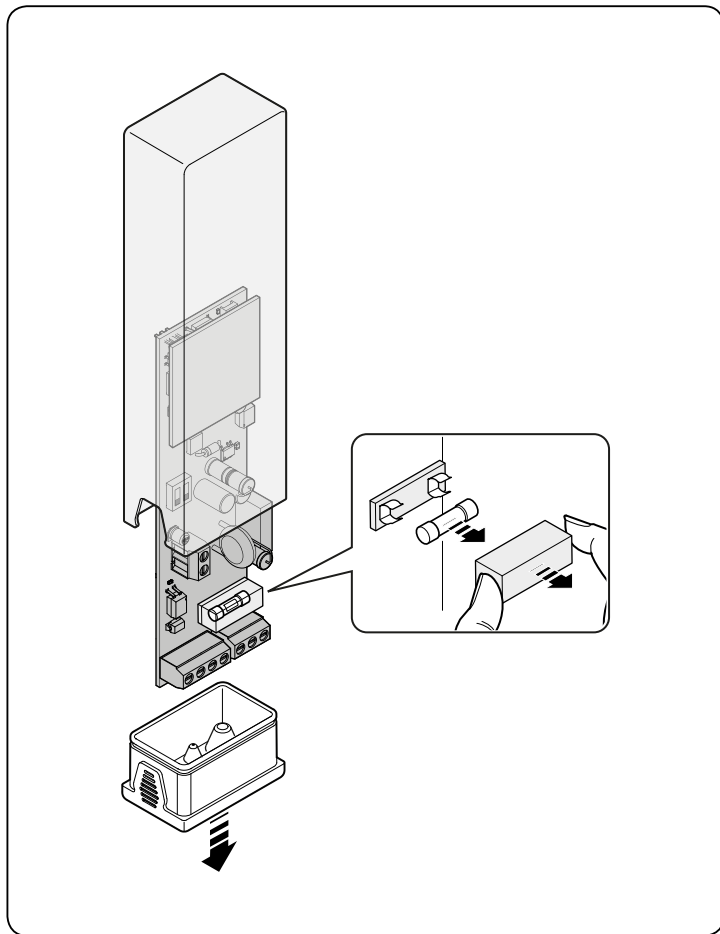

6 - CARATTERISTICHE TECNICHE

Input	
Tensione	230Vac \pm 10%
Frequenza	50 Hz
Potenza assorbita (stand-by)	550 mW
Output	
Tensione	230Vac \pm 10%
Frequenza	50 Hz
Massima Corrente di spunto	80 A
Ambiente	
Temperatura di funzionamento	-40 + 55° C
Temperatura di stoccaggio	-40 + 70° C
IP	54
Dimensioni	43 x 25 x 150 mm
Peso	100 g

7 - SMALTIMENTO DEL PRODOTTO

Come per le operazioni d'installazione, anche al termine della vita di questo prodotto, le operazioni di smantellamento devono essere eseguite da personale qualificato. Questo prodotto è costituito da vari tipi di materiali: alcuni possono essere riciclati, altri devono essere smaltiti. Informatevi sui sistemi di riciclaggio o smaltimento previsti dai regolamenti vigenti sul vostro territorio, per questa categoria di prodotto.

Attenzione! – alcune parti del prodotto possono contenere sostanze inquinanti o pericolose che, se disperse nell'ambiente, potrebbero provocare effetti dannosi sull'ambiente stesso e sulla salute umana.



Come indicato dal simbolo a lato, è vietato gettare questo prodotto nei rifiuti domestici. Eseguire quindi la "raccolta separata" per lo smaltimento, secondo i metodi previsti dai regolamenti vigenti sul vostro territorio, oppure riconsegnare il prodotto al venditore nel momento dell'acquisto di un nuovo prodotto equivalente.

Attenzione! – i regolamenti vigenti a livello locale possono prevedere pesanti sanzioni in caso di smaltimento abusivo di questo prodotto. Il materiale dell'imballo del prodotto deve essere smaltito nel pieno rispetto della normativa locale.

DICHIARAZIONE CE DI CONFORMITÀ

Dichiarazione in accordo alla Direttiva 1999/5/CE

Nota – Il contenuto di questa dichiarazione corrisponde a quanto dichiarato nel documento ufficiale depositato presso la sede di Nice S.p.a., e in particolare, alla sua ultima revisione disponibile prima della stampa di questo manuale. Il testo qui presente è stato riadattato per motivi editoriali. Copia della dichiarazione originale può essere richiesta a Nice S.p.a. (TV) I.

Numero dichiarazione: **520/TTD0110** Revisione: **0** Lingua: **IT**

Il sottoscritto Mauro Sordini in qualità di Amministratore Delegato, dichiara sotto la propria responsabilità che il prodotto: • **Nome produttore:** NICE S.p.A. • **Indirizzo:** Via Pezza Alta n°13, 31046 Rustignè di Oderzo (TV) Italy • **Tipo di prodotto:** Ricevitore radio 1-10 V per alimentatori elettronica dimmerabili • **Modello / Tipo:** TTD0110 • **Accessori:** -

Risulta conforme ai requisiti essenziali richiesti dall'articolo 3 della seguente direttiva comunitaria, per l'uso al quale i prodotti sono destinati:

- Direttiva 1999/5/CE DEL PARLAMENTO EUROPEO E DEL CONSIGLIO del 9 marzo 1999 riguardante le apparecchiature radio e le apparecchiature terminali di comunicazione e il reciproco riconoscimento della loro conformità, secondo le seguenti norme armonizzate:
 - Protezione della salute (art. 3(1)(a)): EN 62479:2010
 - Sicurezza elettrica (art. 3(1)(a)): EN 60950-1:2006+A1:2010+A12:2011+A11:2009+A2:2013
 - Compatibilità elettromagnetica (art. 3(1)(b)): EN 301 489-1 V1.9.2:2011, EN 301 489-3 V1.6.1:2013
 - Spettro radio (art. 3(2)): EN 300 220-2 V2.4.1:2012

Inoltre il prodotto risulta conforma a quanto previsto dalle seguenti direttive comunitarie:

- Direttiva 2006/95/CE DEL PARLAMENTO EUROPEO E DEL CONSIGLIO del 12 dicembre 2006 concernente il ravvicinamento delle legislazioni degli Stati membri relative al materiale elettrico destinato ad essere adoperato entro taluni limiti di tensione, secondo le seguenti norme armonizzate:
EN 60669-2-1:2004+A1:2009+A12:2010
- DIRETTIVA 2004/108/CE DEL PARLAMENTO EUROPEO E DEL CONSIGLIO del 15 dicembre 2004 concernente il ravvicinamento delle legislazioni degli Stati membri relative alla compatibilità elettromagnetica e che abroga la direttiva 89/336/CEE, secondo le seguenti norme armonizzate:
EN 55015:2006+A1:2007+A2:2009, EN 61547:2009, EN 61000-3-2:2006+A1:2009+A2 :2009, EN 61000-3-3:2013

Oderzo, 9 dicembre 2014

Ing. Mauro Sordini (Amministratore Delegato)



SOMMAIRE

1	INSTRUCTIONS GÉNÉRALES	1
2	DESCRIPTION DU PRODUIT ET APPLICATION	2
3	RACCORDEMENTS ÉLECTRIQUES	2
4	PROGRAMMATION	4
4.1	Fonction « Curseur »	5
4.2	LED	5
4.3	Procédure d'apprentissage des émetteurs	6
4.3.1	Utilisation du « premier émetteur » (Mémoire Vide)	6
4.3.2	Utilisation d'« autres émetteurs » : Mode 1	7
4.3.3	Utilisation d'« autres émetteurs » : Mode 2	7
4.3.4	Utilisation du « bouton externe » : Mode 2	8
4.4	Effacement de la mémoire	9
4.4.1	Utilisation de l'« émetteur mémorisé »	9
4.4.2	Utilisation du « bouton externe »	9
4.5	Programmation des niveaux de luminosité	10
4.5.1	Utilisation de l'« émetteur mémorisé »	10
4.5.2	Utilisation du « bouton externe »	11
4.6	Programmation du blocage/déblocage de la mémoire	11
4.6.1	Utilisation de l'« émetteur mémorisé »	11
4.6.2	Utilisation du « bouton externe »	12
5	Remplacement du fusible	13
6	CARACTÉRISTIQUES TECHNIQUES	13
7	MISE AU REBUT DU PRODUIT	13

1 - INSTRUCTIONS GÉNÉRALES

- **MISE EN GARDE : Instructions importantes pour la sécurité. Il est important de suivre toutes les instructions fournies étant donné qu'une installation incorrecte est susceptible de provoquer des dommages graves.**
- **ATTENTION : Consignes de sécurité importantes. Pour la sécurité des personnes, il est important de suivre ces instructions. Conserver ces instructions.**
 - Les enfants ne doivent pas jouer avec l'appareil.
 - Ne pas laisser les enfants jouer avec les dispositifs de commande du produit. Conserver les émetteurs hors de la portée des enfants.
 - Contrôler fréquemment l'installation, notamment les câbles, les éventuels signes d'usure ou détériorations. Ne pas utiliser l'installation en cas de réparations ou de réglages nécessaires étant donné qu'une panne peut provoquer des blessures.
 - Le nettoyage et l'entretien qui doivent être effectués par l'utilisateur ne doivent pas être confiés à des enfants sans surveillance.
- **ATTENTION** : afin d'éviter tout danger dû au réarmement accidentel du disjoncteur, cet appareil doit être alimenté par le biais d'un dispositif de manœuvre externe (ex. : temporisateur) ou bien être connecté à un circuit régulièrement alimenté ou déconnecté par la ligne.
- Avant d'effectuer l'installation, contrôler les « Caractéristiques techniques du produit » (fournies dans ce manuel). Dans le cas contraire, NE PAS procéder à l'installation.
- Les matériaux d'emballage du produit doivent être mis au rebut dans le plein respect des normes locales en vigueur.
- Avant l'installation du produit, s'assurer que tout le matériel à utiliser est en excellent état et adapté à l'usage prévu.
- Le fabricant décline toute responsabilité en cas de dommages patrimoniaux causés à des biens ou à des personnes dérivant du non-respect des instructions de montage. Dans ces cas, la garantie pour défauts matériels est exclue.
- Avant toute intervention (maintenance, nettoyage), il faut toujours débrancher le produit du secteur.
- Sur le réseau d'alimentation de l'installation, prévoir un disjoncteur (non fourni) avec une distance d'ouverture entre les contacts en mesure de garantir la coupure complète du courant électrique dans les

conditions prévues pour la catégorie de surtension III.

- Pendant l'installation, manipuler le produit avec soin en évitant tout écrasement, choc, chute ou contact avec des liquides de quelque nature que ce soit. Ne pas positionner le produit près de sources de chaleur, ni l'exposer à des flammes nues. Toutes ces actions peuvent l'endommager et créer des dysfonctionnements ou des situations de danger. Le cas échéant, suspendre immédiatement l'installation et s'adresser au service après-vente.

2 - DESCRIPTION DU PRODUIT ET APPLICATION

TTD0110 est un régulateur de tension 1-10 Volts qui gère la puissance de sortie des blocs d'alimentation, avec sortie réglable, pour sources lumineuses. **Toute autre utilisation doit être considérée comme impropre et interdite !**

Le régulateur dispose d'un récepteur radio qui fonctionne à une fréquence de 433.92 MHz avec un code tournant.

Il peut être commandé avec les produits Nice compatibles (**Tableau 1**) et avec un bouton externe pour l'allumage, l'extinction et le réglage de l'intensité lumineuse de la lampe.

TABLEAU 1

Série	Modèle	Touches	Programmation	Fonctions
Nice Era	Era P	▲	Mode 1 (chapitre 4)	Curseur (chapitre 4)
		■		
	Era W	▼		
	Era MiniWay			
	Era One	○	Mode 2 (chapitre 4)	
	Era Inti			
NiceWay	NiceWay	▲	Mode 1 (chapitre 4)	
Nice Ergo	Ergo	■		
		▼		
Nice Flor	Flor-m	○	Mode 2 (chapitre 4)	
Nice Very	Very VR	▲	Mode 1 (chapitre 4)	
		■		
		▼		

Nice Home	Touch HSTS2	afficheur	Mode 1 (chapitre 4)	
	HSTX8	○	Mode 2 (chapitre 4)	

3 - RACCORDEMENTS ÉLECTRIQUES

Instructions spécifiques :

- **Le produit est soumis à une tension électrique dangereuse : l'ouverture de l'armoire et toutes les connexions électriques doivent être effectuées après avoir coupé le courant électrique.**
- **Ne jamais couper le câble de l'antenne qui est soumis à une tension électrique dangereuse.**

Pour effectuer les raccordements électriques, ouvrir le TTD0110 (**fig. 1**) et procéder comme indiqué sur les **fig. 2** et **3** (exemple de connexion électrique complète) :

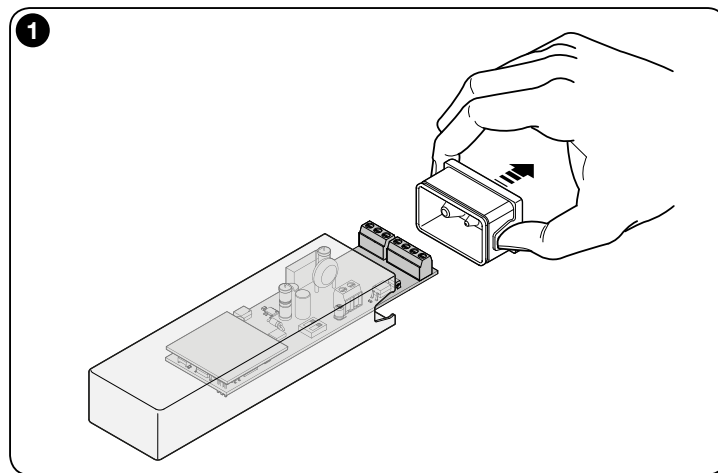

2

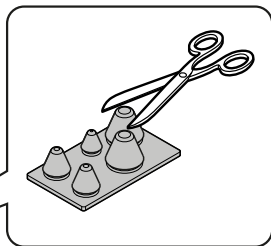
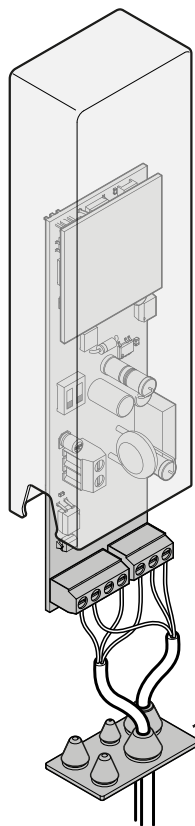

3

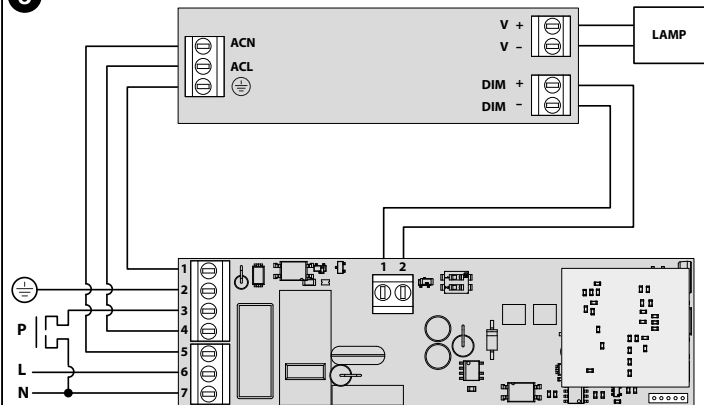

	tension d'alimentation	bornes
Entrée / Alimentation TTD0110	220 - 240 Vac	7 - phase N 6 - neutre F 2 - terre T
Sortie / Alimentation circuit de pilotage externe		5 - phase N 4 - neutre F 1 - terre T
Sortie / Bouton externe		3 - bouton P 7 - neutre N
	basse tension	bornes
Sortie / Circuit de pilotage externe : réglage 1-10 V, 0-10 V, 2-10 V ou PWM	variateur connecté au bloc d'alimentation/ circuit de pilotage	1 (-) 2 (+)

Le produit présente deux commutateurs DIP (**fig. 4**) qui permettent de sélectionner le type de charge à connecter à la sortie :

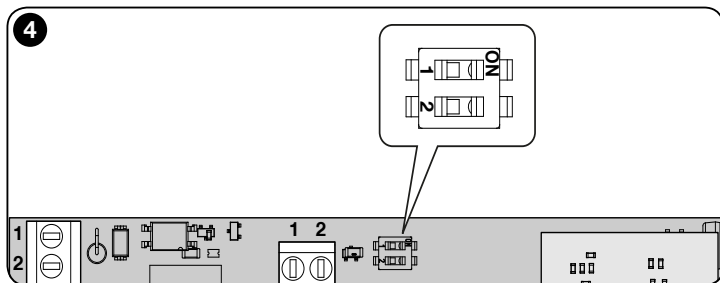

Dip 1	Dip 2	Description
Off	Off	Sortie 2-10 V
On	Off	Sortie 1-10 V
Off	On	Sortie 0-10 V
On	On	PWM (1 kHz)

Remarque : contrôler le type de charge dans les caractéristiques techniques du dispositif à connecter.

4 - PROGRAMMATION



La programmation du TTD0110 doit être effectuée à l'aide d'un émetteur mémorisé en « Mode 1 » ou du bouton externe.

Il est possible de mémoriser jusqu'à 30 émetteurs en « **Mode 1** » ou en « **Mode 2** » en fonction du comportement souhaité :

TABLEAU 2

Mode 1 : attribuer automatiquement les trois commandes aux trois premières touches de l'émetteur

Touches	Fonction
 / ①	Dimmer up

 / ②	Toggle
 / ③	Dimmer down
④ ...	-

Mode 2 : associer librement une commande parmi celles disponibles

Fonction	Procédure	Description
Dimmer up	1 simple pression de la touche (< 1 seconde)	La luminosité de la lampe augmente légèrement à moins qu'elle n'ait déjà atteint son niveau maximum.
	1 pression prolongée de la touche (> 1 seconde)	La luminosité de la lampe augmente jusqu'à atteindre la valeur maximum configurée ou bien jusqu'au relâchement de la touche.
Toggle	à chaque pression de la touche	Le variateur allume (On) ou éteint (Off) la source lumineuse. Valeur de luminosité associée à « On » : dernier seuil de luminosité mémorisé dans le variateur. La valeur est automatiquement mémorisée par le variateur à chaque fois que la lampe s'éteint (dans ce cas, la valeur mémorisée équivaldra à la luminosité de la lampe avant extinction) ou, de toute façon, environ 60 secondes après la dernière variation de luminosité (dans ce cas, c'est la dernière valeur de luminosité qui est mémorisée).
Dimmer down	1 simple pression de la touche (< 1 seconde)	La luminosité de la lampe diminue légèrement à moins qu'elle n'ait déjà atteint son niveau minimum.

	1 pression prolongée de la touche (> 1 seconde)	La luminosité de la lampe diminue jusqu'à atteindre la valeur minimum configurée ou bien jusqu'au relâchement de la touche.
Dimmer up Toggle Dimmer down ...	à chaque pression de la touche	Les différentes fonctions sont exécutées alternativement.

4.1 - Fonction « Curseur »

Permet l'allumage et l'extinction des lampes ainsi que le réglage dynamique de la luminosité. La surface capacitive se comporte comme un curseur (slider) :

Procédure	Description
appui léger du curseur	commande de position absolue
défilement sur le curseur	progression de commandes pour régler la luminosité de manière dynamique : envoi de commandes quelle que soit la position du doigt

4.2 - LED (fig. 5)

La LED sur la partie inférieure du TTD0110 émet différents signaux concernant aussi bien les procédures de programmation que les signalisations générales :

Clignote-ments	Couleur	Exécution	Description
6	vert	au terme d'une procédure de mémorisation d'un émetteur	la mémoire est pleine, impossible de mémoriser l'émetteur
2	vert	lors de la mise sous tension du variateur	sa mémoire est vide (= aucun émetteur mémorisé)



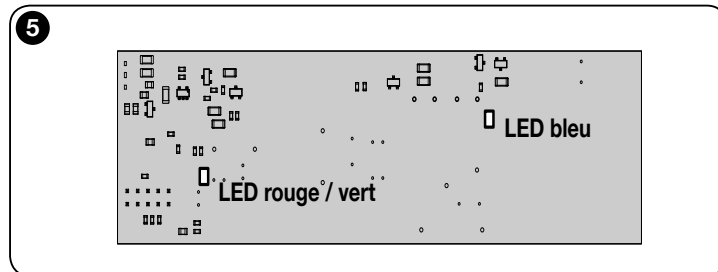



2	rouge	durant une procédure de programmation quelconque	une erreur s'est produite
allumée en permanence	bleu	s'allume à l'activation du bloc d'alimentation / circuit de pilotage	Tension bornes 5 et 4



Dans ce manuel, les procédures de programmation sont expliquées par le biais d'icônes dont la signification est indiquée dans le tableau suivant :

LÉGENDE	
LED : comportement durant les procédures de programmation	
Symbole	Description
	ALLUMÉE
	ÉTEINTE
	clignotement LONG
	clignotement BREF
	clignotement RAPIDE







autres symboles	
Symbole	Description
	METTRE HORS TENSION
	METTRE SOUS TENSION
	LAMPE ALLUMÉE
	LAMPE ÉTEINTE
	VALEUR SOUHAITÉE DE LA LUMINOSITÉ DE LA LAMPE
	ENFONCER BRIÈVEMENT
	MAINTENIR LA TOUCHE DE L'ÉMETTEUR ENFONCÉE
	RELÂCHER LA TOUCHE DE L'ÉMETTEUR
	MAINTENIR EN MÊME TEMPS LA TOUCHE DE L'ÉMETTEUR ENFONCÉE
	RELÂCHER EN MÊME TEMPS LA TOUCHE DE L'ÉMETTEUR
	TOUCHES ÉMETTEUR
	TOUCHES ÉMETTEUR

	ENFONCER BRIÈVEMENT LA TOUCHE DE L'ÉMETTEUR SOUHAITÉE
	OBSERVER / CHOISIR
	ATTENDRE QUE ...
 2 secondes	ATTENDRE PENDANT UN CERTAIN DÉLAI
	ENFONCER BRIÈVEMENT LA TOUCHE EXTERNE
	MAINTENIR LA TOUCHE EXTERNE ENFONCÉE
	RELÂCHER LA TOUCHE EXTERNE

4.3 - Procédure d'apprentissage des émetteurs









4.3.1 - Utilisation du « premier émetteur » (Mémoire Vide)

Cette procédure permet d'associer un émetteur au variateur en « Mode 1 ».

01.		 2 secondes		2  led verte
02.	dans les 5 secondes	 pendant 8 secondes		
03.	2  led verte : mémorisation OK			
	2  led rouge : mémorisation INCOMPLÈTE <i>dans ce cas, répéter toute la procédure depuis le début</i>			



4.3.2 - Utilisation d'« autres émetteurs » : Mode 1













Cette procédure permet d'associer un émetteur au variateur en « Mode 1 ».









01.	NOUVEL émetteur			1  led rouge
		pendant 8 secondes		
02.	ANCIEN émetteur déjà mémorisé		x 3 	
03.	NOUVEL émetteur		pendant 5 secondes	
04.	2  led verte : mémorisation OK 2  led rouge : mémorisation INCOMPLÈTE <i>dans ce cas, répéter toute la procédure depuis le début</i>			

4.3.3 - Utilisation d'« autres émetteurs » : Mode 2

Cette procédure permet d'associer un émetteur au variateur en « Mode 2 ».











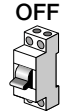





01.	ANCIEN émetteur déjà mémorisé			1  led verte
		pendant 8 secondes		















02.	ANCIEN émetteur déjà mémorisé			2  led verte
		pendant 8 secondes		
03.	ANCIEN émetteur déjà mémorisé	 choisir la fonction souhaitée :		
	Dimmer Up > Toggle > Dimmer Down		x 1 	
	Dimmer Up		x 2 	
	Dimmer Down		x 3 	
	Toggle		x 4 	
	Niveau 1		x 5 	
	Niveau 2		x 6 	
	Niveau 3		x 7 	
	Niveau 4		x 8 	
	OFF		x 9 	

	ON	x 10 
04.	 5 secondes = 	...  led verte ... clignotements selon la fonction choisie
05.	 touche de l'émetteur souhaitée	 led verte 3 s = 
06.	2  led verte : mémorisation OK	

4.3.4 - Utilisation du « bouton externe » : Mode 2

Cette procédure permet d'associer un émetteur au variateur en « Mode 2 ».

01.	 OFF		 ON		 led verte	 3 s = 		
02.		 led verte	 3 s = 		 au 5ème 			
03.	 choisir la fonction souhaitée							
	Dimmer Up > Toggle > Dimmer Down					x 1 		

	Dimmer Up	x 2 
	Dimmer Down	x 3 
	Toggle	x 4 
	Niveau 1	x 5 
	Niveau 2	x 6 
	Niveau 3	x 7 
	Niveau 4	x 8 
	OFF	x 9 
	ON	x 10 
04.	 5 secondes	 led verte ... clignotements selon la fonction choisie
05.	 touche de l'émetteur souhaitée	 led verte 3 s = 
06.	2  led verte : mémorisation OK	

4.4 - Effacement de la mémoire

4.4.1 - Utilisation de l'« émetteur mémorisé »

À l'aide d'un émetteur mémorisé en « Mode 1 », la mémoire peut être intégralement ou partiellement effacée.

01.			1 led verte	
02.			2 led verte	
03.			3 led verte	
04.			4 led verte	
05.	choisir la fonction souhaitée			
	N'effacer que les émetteurs			
	N'effacer que les paramètres			

	N'effacer que les émetteurs et les paramètres		
06.	5 secondes	2 led verte	
	2 led rouge : mémorisation INCOMPLÈTE <i>dans ce cas, répéter toute la procédure depuis le début</i>		

4.4.2 - Utilisation du « bouton externe »

01.					led verte		3 s =	
02.		led verte		3 s =			au 2ème	
03.		led verte		3 s =			au 5ème	
04.	choisir la fonction souhaitée							

	N'effacer que les émetteurs	x 1	
	N'effacer que les paramètres	x 2	
	N'effacer que les émetteurs et les paramètres	x 3	
05.	5 secondes	led verte ... clignotements selon la fonction choisie	
06.		led verte	3 s =
07.	2 led verte : mémorisation OK		

4.5 - Programmation des niveaux de luminosité

4.5.1 - Utilisation de l'« émetteur mémorisé »

Cette procédure peut être effectuée uniquement à l'aide d'un émetteur déjà mémorisé en « Mode 1 ».

Le niveau de luminosité mémorisé ne pourra être rappelé qu'après avoir été associé à une touche d'un émetteur programmé en Mode 2.

01.		3 s	1 led verte	
02.		3 s	2 led verte	

03.	Se servir des touches ▲ - ▼ pour régler la luminosité	 valeur intensité de lumière souhaitée	10 secondes	2 led verte	
04.	choisir la fonction souhaitée				
	Niveau 1		=	2 led verte	
	Niveau 2		=	2 led verte	
	Niveau 3		=	2 led verte	
	Niveau 4		=	2 led verte	

4.5.2 - Utilisation du « bouton externe »

01.							
02.							
03.						au 2ème	
04.	Régler la luminosité de la lampe sur la valeur souhaitée à l'aide du bouton externe :						
	1ère pression prolongée du bouton externe = augmentation de la luminosité jusqu'au relâchement du bouton						
	2ème pression prolongée du bouton externe = diminution de la luminosité jusqu'au relâchement du bouton						
ATTENTION ! = fonction « Toggle » (ON/OFF)							
05.				valeur intensité de lumière souhaitée	5 secondes	= 2	+
06.		choisir le niveau souhaité					

	Niveau 1	x 1	
	Niveau 2	x 2	
	Niveau 3	x 3	
	Niveau 4	x 4	
07.		5 secondes	led verte + ... clignotements selon le niveau choisi
08.			
	led verte	3 s =	
09.	2		led verte : mémorisation OK

4.6 - Programmation du blocage/déblocage de la mémoire

4.6.1 - Utilisation de l'« émetteur mémorisé »

Cette procédure peut être effectuée uniquement à l'aide d'un émetteur déjà mémorisé en « Mode 1 ».

01.			1	led verte	
-----	--	--	----------	------------------	--

02.			2 led verte	
03.			3 led verte	
04.			4 led verte	
05.	choisir la fonction souhaitée			
	Bloquer la mémoire		2 ; ■	
	Débloquer la mémoire		2 ; ■	

4.6.2 - Utilisation du « bouton externe »

01.	OFF 		ON 			
			led verte	3 s = ■		

02.		led verte	3 s = ■			au 2ème
03.		led verte	3 s = ■			au 2ème
04.	choisir la fonction souhaitée					
	Bloquer la mémoire				x 1	
	Débloquer la mémoire				x 2	
05.	5 secondes	led verte + ... clignotements selon la fonction choisie				
06.		led verte	3 s = ■			
07.	2 led verte : mémorisation OK					

5 - Remplacement du fusible

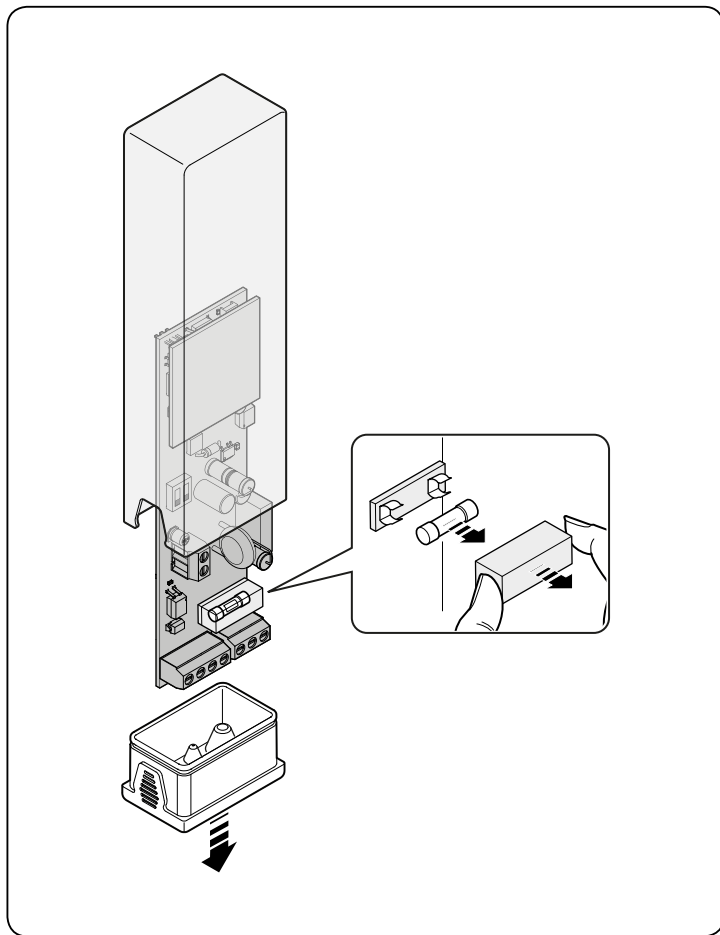

6 - CARACTÉRISTIQUES TECHNIQUES

Entrée	
Tension	230 Vac \pm 10%
Fréquence	50 Hz
Puissance absorbée (mode veille)	550 mW
Sortie	
Tension	230 Vac \pm 10%
Fréquence	50 Hz
Courant de démarrage maximum	80 A
Environnement	
Température de fonctionnement	-40 + 55° C
Température de stockage	-40 + 70° C
IP	54
Dimensions	43 x 25 x 150 mm
Poids	100 g

7 - MISE AU REBUT DU PRODUIT

Comme pour l'installation, à la fin de la durée de vie de ce produit, les opérations de démantèlement doivent être effectuées par du personnel qualifié. Ce produit se compose de divers matériaux : certains peuvent être recyclés, d'autres doivent être mis au rebut. Informez-vous sur les systèmes de recyclage ou de mise au rebut prévus par les normes en vigueur dans votre région pour cette catégorie de produit.

Attention ! Certains composants du produit peuvent contenir des substances polluantes ou dangereuses qui pourraient, s'ils sont jetés dans la nature, avoir des effets nuisibles sur l'environnement et sur la santé des personnes.



Comme l'indique le symbole ci-contre, il est interdit de jeter ce produit avec les ordures ménagères. Procéder à la « collecte différenciée » des composants pour leur traitement conformément aux méthodes prescrites par les normes locales en vigueur ou restituer le produit au vendeur lors de l'achat d'un nouveau produit équivalent.

Attention ! – les règlements locaux en vigueur peuvent prévoir de lourdes sanctions en cas d'élimination prohibée de ce produit. Les matériaux de l'emballage du produit doivent être mis au rebut dans le plein respect des normes locales en vigueur.

ÍNDICE

1	ADVERTENCIAS GENERALES	1
2	DESCRIPCIÓN DEL PRODUCTO Y USO PREVISTO	2
3	CONEXIONES ELÉCTRICAS	2
4	PROGRAMACIÓN	4
4.1	Función “Slider”	5
4.2	LED	5
4.3	Procedimiento de adquisición de los transmisores	6
4.3.1	Uso “Primer transmisor” (Memoria Vacía)	6
4.3.2	Uso “Ulteriores transmisores”: Modo 1	7
4.3.3	Uso “Ulteriores transmisores”: Modo 2	7
4.3.4	Uso “Tecla externa”: Modo 2	8
4.4	Borrado de la memoria	9
4.4.1	Uso “Transmisor memorizado”	9
4.4.2	Uso “Tecla externa”	9
4.5	Programación de los niveles de luminosidad	10
4.5.1	Uso “Transmisor memorizado”	10
4.5.2	Uso “Tecla externa”	11
4.6	Programación del bloqueo y desbloqueo de la memoria	11
4.6.1	Uso “Transmisor memorizado”	11
4.6.2	Uso “Tecla externa”	12
5	Sustitución del fusible	13
6	CARACTERÍSTICAS TÉCNICAS	13
7	ELIMINACIÓN DEL PRODUCTO	13

1 - ADVERTENCIAS GENERALES

- **ADVERTENCIA: Instrucciones importantes para la seguridad. Seguir todas las instrucciones: una instalación incorrecta puede provocar daños graves.**
- **ATENCIÓN: Importantes instrucciones de seguridad. Para la seguridad de las personas es importante seguir estas instrucciones. Conservar estas instrucciones.**
- Los niños no deben jugar con el aparato.
- No permitir que los niños jueguen con los dispositivos de mando del producto. Mantener los mandos a distancia fuera del alcance de los niños.
- Inspeccionar la instalación con frecuencia, especialmente los cables, para identificar signos de desgaste o daños. No utilizar la instalación si es necesaria una reparación o una regulación: el uso de una instalación averiada puede provocar lesiones.
- La limpieza y el mantenimiento deben ser efectuados por el usuario y no por niños sin vigilancia:
- **ATENCIÓN:** para evitar cualquier peligro debido al restablecimiento accidental del interruptor térmico, el aparato no debe alimentarse mediante un dispositivo de maniobra externo, como un temporizador, ni debe conectarse a un circuito que regularmente se conecte y desconecte de la alimentación.
- Antes de comenzar la instalación, verificar las “Características técnicas del producto” (en este manual). NO proceder con la instalación si el producto no es adecuado.
- El material del embalaje del producto debe desecharse de conformidad con la normativa local.
- Antes de proceder a la instalación del producto, comprobar que todo el material que se vaya a utilizar esté en perfectas condiciones y que sea apto para el uso previsto.
- El fabricante no asume ninguna responsabilidad ante daños patrimoniales, de bienes o de personas, derivados del incumplimiento de las instrucciones de montaje. En estos casos, la garantía por defectos de material queda sin efecto.
- Antes de realizar cualquier operación en la instalación (limpieza, mantenimiento) hay que desconectar el aparato de la red de alimentación.
- En la red de alimentación de la instalación, colocar un dispositivo de desconexión (no suministrado) con una distancia de apertura de los

contactos que permita la desconexión completa en las condiciones dictadas por la categoría de sobretensión III.

- Durante la instalación, tratar el producto con cuidado evitando aplastamientos, caídas o contactos con cualquier tipo de líquido. No colocar el producto cerca de fuentes de calor y no exponerlo a llamas libres. Todas estas acciones pueden dañarlo y provocar defectos de funcionamiento o situaciones de peligro. En tal caso, suspender inmediatamente la instalación y acudir al Servicio de Asistencia.

2 - DESCRIPCIÓN DEL PRODUCTO Y USO PREVISTO

TTD0110 es un regulador de tensión 1-10 V que controla la salida de potencia de alimentadores con salida regulable por dimmer para fuentes luminosas. **Cualquier otro uso es inadecuado y está prohibido.**

El regulador incorpora un receptor de radio que funciona a la frecuencia de 433.92 MHz, con codificación "rolling code".

El mando es posible mediante los productos Nice compatibles (**Tabla 1**) y una tecla externa con la cual encender, apagar y regular la intensidad luminosa de la lámpara.

TABLA 1				
Serie	Modelo	Teclas	Programación	Funciones
Nice Era	Era P	▲	Modo 1 (capítulo 4)	Slider (capítulo 4)
	Era W	■		
	Era MiniWay	▼		
	Era One	○	Modo 2 (capítulo 4)	
	Era Inti			
NiceWay	NiceWay	▲	Modo 1 (capítulo 4)	
Nice Ergo	Ergo	■		
		▼		
Nice Flor	Flor-m	○	Modo 2 (capítulo 4)	

Ncice Very	Very VR	▲ ■ ▼	Modo 1 (capítulo 4)	
Nice Home	Touch HSTS2	display	Modo 1 (capítulo 4)	
	HSTX8	○	Modo 2 (capítulo 4)	

3 - CONEXIONES ELÉCTRICAS

Advertencias específicas:

- **El producto está sujeto a tensión eléctrica peligrosa: la apertura del contenedor y todas las conexiones eléctricas deben realizarse en ausencia de tensión eléctrica.**
- **No cortar por ningún motivo el cable de la antena; está sujeto a tensión eléctrica peligrosa.**

Para realizar las conexiones eléctricas es necesario abrir TTD0110 (**fig. 1**) y proceder como se indica en la **fig. 2 e 3** (ejemplo de conexión eléctrica completa):

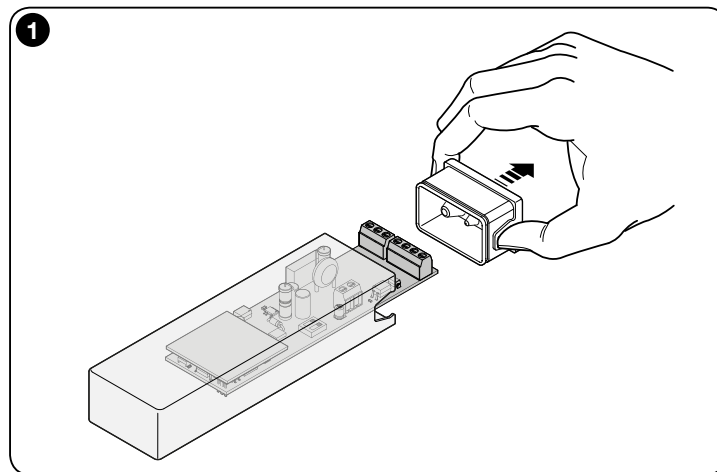

2

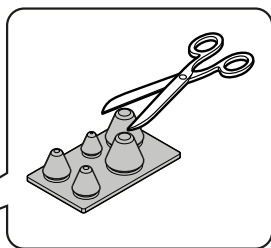
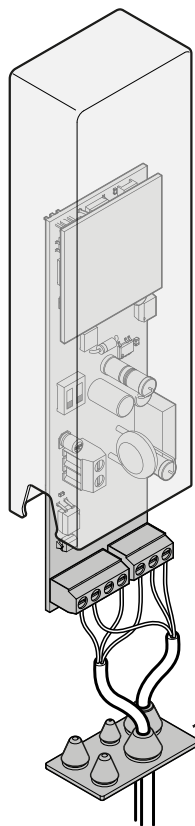

3

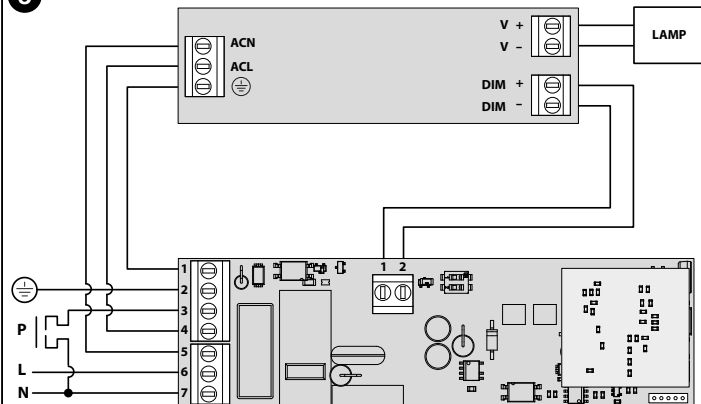

	tensión de red	bornes
Entrada / Alimentación TTD0110	220 - 240 Vac	7 - fase N 6 - neutro F 2 - tierra T
Salida / Alimentación Driver externo		5 - fase N 4 - neutro F 1 - tierra T
Salida / Tecla externa		3 - tecla P 7 - neutro N
	baja tensión	bornes
Salida / Driver externo: regulación 1-10 V o 0-10 V o 2-10 V o PWM	dimmer conectado a alimentador/driver	1 (-) 2 (+)

El producto presenta dos microinterruptores (**fig. 4**) que permiten seleccionar el tipo de carga que se conectará a la salida:

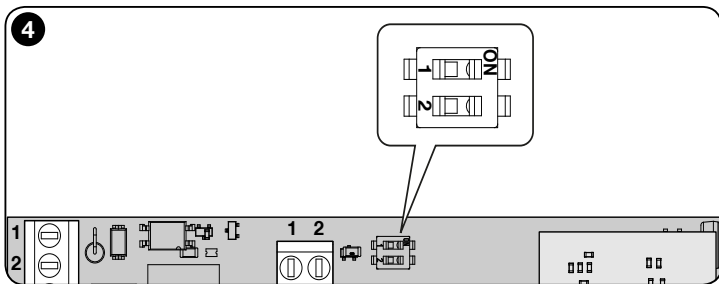

Dip 1	Dip 2	Descripción
Off	Off	Salida 2-10 V
On	Off	Salida 1-10 V
Off	On	Salida 0-10 V
On	On	PWM (1k Hz)

Nota: verificar el tipo de carga en las características técnicas del dispositivo que se va a conectar.

4 - PROGRAMACIÓN

La programación de TTD0110 debe realizarse exclusivamente con un transmisor memorizado en “Modo 1” o con la tecla externa.

Se pueden memorizar hasta 30 transmisores en “**Modo 1**” o en “**Modo 2**” para obtener diferentes comportamientos:

TABLA 2

Modo 1: asignar automáticamente los tres mandos a las primeras tres teclas del transmisor

Teclas	Función
▲ / ①	Dimmer up
■ / ②	Toggle

▼ / ③	Dimmer down
④ ...	-

Modo 2: asociar libremente uno de los mandos disponibles

Función	Procedimiento	Descripción
Dimmer up	1 presión breve de la tecla (< 1 segundo)	la luminosidad de la lámpara aumenta en un pequeño porcentaje, salvo que ya esté en el valor máximo
	1 presión prolongada de la tecla (> 1 segundo)	la luminosidad de la lámpara aumenta hasta alcanzar el valor máximo programado o hasta que se suelta la tecla
Toggle	cada presión de la tecla	el dimmer enciende (On) o apaga (Off) la fuente luminosa conectada. Valor de luminosidad asociado a “On”; último umbral de luminosidad memorizado en el dimmer. El valor se memoriza automáticamente en el dimmer cuando la lámpara pasa de encendida a apagada (en este caso, el valor memorizado será el de la luminosidad de la lámpara antes del apagado) o, en todo caso, a los 60 segundos de la última variación de luminosidad (en este caso, se memoriza el último valor).
Dimmer down	1 presión breve de la tecla (< 1 segundo)	la luminosidad de la lámpara disminuye en un pequeño porcentaje, salvo que ya esté en el valor mínimo
	1 presión prolongada de la tecla (> 1 segundo)	la luminosidad de la lámpara disminuye hasta alcanzar el valor mínimo programado o hasta que se suelta la tecla

Dimmer up Toggle Dimmer down ...	cada presión de la tecla	las distintas funciones se ejecutan de modo alterno
--	---------------------------------	---

4.1 - Función “Slider”

Permite el encendido / apagado de las lámparas y la regulación dinámica de la luminosidad. La superficie capacitiva se comporta como un cursor (slider):

Procedimiento	Descripción
toque breve del slider	mando de posicionamiento absoluto
desplazamiento sobre el slider	progresión de mandos para regular la luminosidad de modo dinámico: envío de mandos independientemente de la posición del dedo

4.2 - LED (fig. 5)

El Led en la parte inferior de TTD0110, emite varias señales tanto genéricas como durante los procedimientos de programación:

Parpadeos	Color	Ejecución	Descripción
6	verde	al término de un procedimiento de memorización de un transmisor	la memoria está llena, no es posible memorizar el transmisor
2	verde	cuando se alimenta el dimmer	tiene la memoria vacía (= ningún transmisor memorizado)
2	rojo	durante cualquier procedimiento de programación	se ha cometido un error
encendido fijo	azul	se accede al activarse el alimentador / driver	Tensión bornes 5 y 4







5



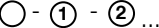

En este manual los procedimientos de programación se explican mediante iconos cuyo significado se indica en la tabla siguiente:

LEYENDA	
LED: comportamiento durante los procedimientos de programación	
Símbolo	Descripción
	ENCENDIDO
	APAGADO
	parpadeo LARGO
	parpadeo BREVE
	parpadeo RÁPIDO
otros símbolos	
Símbolo	Descripción
	DESCONECTAR LA ALIMENTACIÓN

ES







	CONECTAR LA ALIMENTACIÓN
	LÁMPARA ENCENDIDA
	LÁMPARA APAGADA
	VALOR DESEADO DE LUMINOSIDAD DE LA LÁMPARA
	PULSAR BREVEMENTE
	MANTENER PULSADA LA TECLA DEL TRANSMISOR
	SOLTAR LA TECLA DEL TRANSMISOR
	MANTENER PULSADA SIMULTÁNEAMENTE LA TECLA DEL TRANSMISOR
	SOLTAR SIMULTÁNEAMENTE LA TECLA DEL TRANSMISOR
	TECLAS TRANSMISOR
	TECLAS TRANSMISOR
	PULSAR BREVEMENTE LA TECLA DESEADA DEL TRANSMISOR
	OBSERVAR / ELEGIR
	ESPERAR HASTA QUE ...
 2 segundos	ESPERAR UN TIEMPO PRECISO

	PULSAR BREVEMENTE LA TECLA EXTERNA
	MANTENER PULSADA LA TECLA EXTERNA
	SOLTAR LA TECLA EXTERNA

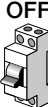
4.3 - Procedimiento de adquisición de los transmisores









4.3.1 - Uso “Primer transmisor” (Memoria Vacía)

Este procedimiento permite asociar un transmisor al dimmer en “**Modo 1**”.

01.		 2 segundos		2  led verde
02.	en un plazo de 5 segundos	 durante 8 segundos		
03.	2  led verde: memorización OK			
	2  led rojo: memorización NO CONCLUIDA <i>en este caso, repetir el procedimiento desde el comienzo</i>			



4.3.2 - Uso “Ulteriores transmisores”: Modo 1













Este procedimiento permite asociar un transmisor al dimmer en “**Mo-
do 1**”.

01.	NUEVO transmisor	 durante 8 segundos		1  led rojo
02.	transmisor ANTERIOR ya memorizado		x 3 	
03.	NUEVO transmisor	 durante 5		
04.	2  led verde: memorización OK 2  led rojo: memorización NO CONCLUIDA en este caso, repetir el procedimiento desde el comienzo			

4.3.3 - Uso “Ulteriores transmisores”: Modo 2

Este procedimiento permite asociar un transmisor al dimmer en “**Mo-
do 2**”.

01.	ANTERIOR transmisor ya memorizado	 durante 8 segundos		1  led verde
------------	--	--	--	---

02.	ANTERIOR transmisor ya memorizado	 durante 8 segundos		2  led verde
03.	ANTERIOR transmisor ya memorizado		 elegir la función deseada:	
	Dimmer Up > Toggle > Dimmer Down			x 1 
	Dimmer Up			x 2 
	Dimmer Down			x 3 
	Toggle			x 4 
	Nivel 1			x 5 
	Nivel 2			x 6 
	Nivel 3			x 7 
	Nivel 4			x 8 
	OFF			x 9 

	ON	x 10
04.	5 segundos =	... led verde ... parpadeos según la función elegida
05.	tecla deseada del transmisor	led verde 3 s =
06.	2 led verde: memorización OK	

4.3.4 - Uso "Tecla externa": Modo 2

Este procedimiento permite asociar un transmisor al dimmer en "Modo 2".

01.	OFF		ON		led verde	3 s =		
02.		led verde	3 s =		al 5°			
03.	elegir la función deseada							
	Dimmer Up > Toggle > Dimmer Down					x 1		

	Dimmer Up	x 2	
	Dimmer Down	x 3	
	Toggle	x 4	
	Nivel 1	x 5	
	Nivel 2	x 6	
	Nivel 3	x 7	
	Nivel 4	x 8	
	OFF	x 9	
	ON	x 10	
04.	5 segundos	led verde ... parpadeos según la función elegida	
05.	tecla deseada del transmisor	led verde 3 s =	
06.	2 led verde: memorización OK		

4.4 - Borrado de la memoria

4.4.1 - Uso “Transmisor memorizado”











Utilizando un transmisor memorizado en “Modo 1” es posible borrar la memoria total o parcialmente.

01.			1 led verde	
02.			2 led verde	
03.			3 led verde	
04.			4 led verde	
05.	elegir la función deseada			
	Borrar sólo los transmisores			
	Borrar sólo los parámetros			

	Borrar sólo los transmisores y los parámetros		
06.	5 segundos	2 led verde	
	2 led rojo: memorización NO CONCLUIDA <i>en este caso, repetir el procedimiento desde el comienzo</i>		

4.4.2 - Uso “Tecla externa”

01.					led verde		3 s =	
02.		led verde				al 2°		
03.		led verde				al 5°		
04.	elegir la función deseada							





	Borrar sólo los transmisores		x 1 
	Borrar sólo los parámetros		x 2 
	Borrar sólo los transmisores y los parámetros		x 3 
04.	 5 segundos	 led verde ... parpadeos según la función elegida	
05.		 led verde	 3 s = 
06.	2  led verde: memorización OK		

























4.5 - Programación de los niveles de luminosidad

4.5.1 - Uso “Transmisor memorizado”











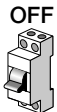















Para ejecutar este procedimiento es necesario tener un transmisor ya memorizado en “Modo 1”.















El nivel de luminosidad memorizado podrá recuperarse sólo después de asociarlo a una tecla de un transmisor programado en Modo 2.

01.		 3 s	1  led verde	
------------	--	--	---	--

02.		 3 s	2  led verde	
03.	Utilizar las teclas ▲ - ▼ para regular la luminosidad	 valor de intensidad de luz deseado	 10 segundos	2  led verde
04.	 elegir la función deseada			
	Nivel 1		 = 	2  led verde
	Nivel 2		 = 	2  led verde
	Nivel 3		 = 	2  led verde
	Nivel 4		 = 	2  led verde

4.5.2 - Uso "Tecla externa"





01.	 OFF 	 ON 	  led verde	 3 s = 	
02.		 led verde	 3 s = 		
03.		 led verde	 3 s = 		 al 2° 
04.	Regular la luminosidad de la lámpara en el valor deseado utilizando la tecla externa:				
	1ª presión prolongada de la tecla externa = aumento de la luminosidad hasta soltar la tecla				
	2ª presión prolongada de la tecla externa = disminución de la luminosidad hasta soltar la tecla				
	¡ATENCIÓN!  = función "Toggle" (ON/OFF)				
05.	 valor de intensidad de luz deseado	 = 2  +  5 segundos			

06.	 elegir el nivel deseado			
	Nivel 1	x 1 		
	Nivel 2	x 2 		
	Nivel 3	x 3 		
	Nivel 4	x 4 		
07.	 5 segundos	 led verde +  nº... parpadeos según el nivel elegido		
08.		 led verde	 3 s = 	
09.	2  led verde: memorización OK			

4.6 - Programación del bloqueo y desbloqueo de la memoria

4.6.1 - Uso "Transmisor memorizado"

Para ejecutar este procedimiento es necesario tener un transmisor ya memorizado en "Modo 1".

01.			1  led verde	
-----	--	--	---	--

02.			2 led verde	
03.			3 led verde	
04.			4 led verde	
05.	elegir la función deseada			
	Bloquear memoria		2 ;	
	Desbloquear memoria		2 ;	

4.6.2 - Uso "Tecla externa"

01.	OFF 		ON 			
			led verde	3 s =		

02.		led verde	3 s =			al 2°
03.		led verde	3 s =			al 2°
04.	elegir la función deseada					
	Bloquear memoria					x 1
	Desbloquear memoria					x 2
05.	5 segundos	led verde + ... parpadeos según la función elegida				
06.		led verde	3 s =			
07.	2 led verde: memorización OK					

5 - Sustitución del fusible

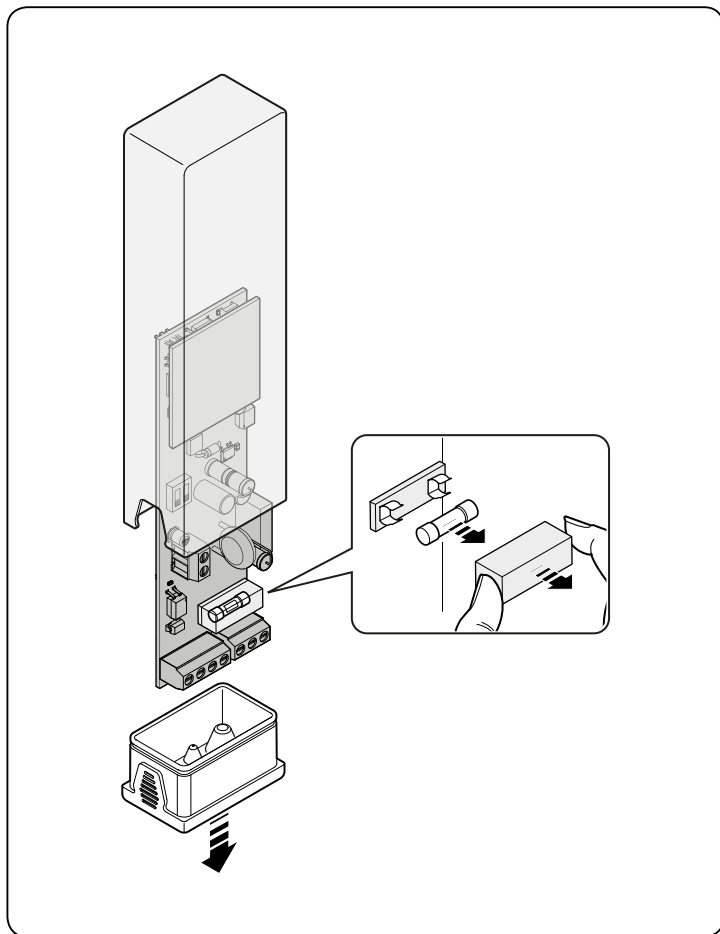

6 - CARACTERÍSTICAS TÉCNICAS

Input	
Tensión	230Vac \pm 10%
Frecuencia	50 Hz
Potencia absorbida (stand-by)	550 mW
Output	
Tensión	230Vac \pm 10%
Frecuencia	50 Hz
Máxima corriente de impulso	80 A
Ambiente	
Temperatura de funcionamiento	-40 + 55° C
Temperatura de almacenaje	-40 + 70° C
IP	54
Dimensiones	43 x 25 x 150 mm
Peso	100 g

7 - ELIMINACIÓN DEL PRODUCTO

Al igual que para las operaciones de instalación, al final de la vida útil de este producto las operaciones de desguace deberán ser llevadas a cabo por personal cualificado. Este producto está formado por varios tipos de materiales, algunos de los cuales pueden reciclarse. Infórmese sobre los sistemas de reciclaje o eliminación previstos por las normativas vigentes en su territorio para esta categoría de producto.

¡Atención! – algunas partes del producto pueden contener sustancias contaminantes o peligrosas que, si se las abandona en el medio ambiente, podrían causar efectos perjudiciales al medio ambiente y la salud humana.



Como lo indica el símbolo que aparece al lado, está prohibido eliminar este producto junto con los desechos domésticos. Realizar la "recogida selectiva" para la eliminación, según los métodos previstos por las normativas locales, o bien entregar el producto al vendedor en el momento de adquirir un nuevo producto equivalente.

¡Atención! – las reglas locales pueden prever sanciones importantes en caso de eliminación ilegal de este producto. El material del embalaje del producto debe eliminarse de conformidad con la normativa local.

INHALT

1	ALLGEMEINE HINWEISE	1
2	BESCHREIBUNG DES PRODUKTS UND BESTIMMUNGSZWECK	2
3	ELEKTRISCHE ANSCHLÜSSE	2
4	PROGRAMMIERUNG	4
4.1	Funktion „Slider“	5
4.2	LED	5
4.3	Selbstlernverfahren Sender	6
4.3.1	Verwendung des „Ersten Senders“ (Leerer Speicher)	6
4.3.2	Verwendung der „Weiteren Sender“: Modus 1	7
4.3.3	Verwendung der „Weiteren Sender“: Modus 2	7
4.3.4	Verwendung der „Externen Taste“: Modus 2	8
4.4	Löschen des Speichers	9
4.4.1	Verwendung eines „Gespeicherten Senders“	9
4.4.2	Verwendung der „Externen Taste“	9
4.5	Programmierung der Helligkeitsstufen	10
4.5.1	Verwendung eines „Gespeicherten Senders“	10
4.5.2	Verwendung der „Externen Taste“	11
4.6	Programmierung der Sperrung und Entsperrung des Speichers	11
4.6.1	Verwendung eines „Gespeicherten Senders“	11
4.6.2	Verwendung der „Externen Taste“	12
5	Ersatz von Sicherungen	13
6	TECHNISCHE DETAILS	13
7	ENTSORGUNG DES PRODUKTS	13

1 – ALLGEMEINE HINWEISE

- **HINWEIS: Sicherheitsrelevante Anweisungen. Alle Anweisungen strikt einhalten. Unkorrekte Installationen können schwerwiegende Schäden verursachen.**
- **ACHTUNG: Wichtige Sicherheitshinweise. Damit die Sicherheit von Personen gewährleistet ist, die folgenden Anweisungen einhalten. Die vorliegende Anleitung gut aufbewahren.**
 - Kinder dürfen nicht mit diesem Gerät spielen.
 - Kinder dürfen nicht mit den Steuervorrichtungen dieses Produkts spielen. Die Fernbedienungen von Kindern fernhalten.
 - Die Anlage häufig überprüfen, insbesondere sicherstellen, dass die Kabel unverseht sind und dass kein Verschleiß oder Beschädigungen vorliegen. Das Produkt nicht verwenden, wenn eine Reparatur oder Einstellung nötig ist, da eine unkorrekte Installation zu Verletzungen führen kann.
 - Kinder dürfen Reinigung- und Wartungsarbeiten, die dem Benutzer obliegen, nur durchführen, wenn sie von einer erwachsenen Person beaufsichtigt werden.
- **ACHTUNG:** Um alle Gefahren im Zusammenhang mit einer unvorhergesehenen Rücksetzung der Temperatursicherung zu verhindern, darf dieses Gerät nicht über eine externe Schaltvorrichtung (z. B. eine Zeitschaltuhr) versorgt oder an einen Stromkreis angeschlossen werden, der regelmäßig ein- oder ausgeschaltet wird.
- Vor der Installation immer die „Technischen Merkmale des Produkts“ prüfen (in der vorliegenden Anleitung enthalten). Die Installation NICHT fortsetzen, wenn eine Inkompatibilität vorliegt.
- Das Verpackungsmaterial des Produkts muss in Übereinstimmung mit den örtlichen Vorschriften entsorgt werden.
- Vor den weiteren Installationsarbeiten des Produkts sicherstellen, dass das gesamte zu verwendende Material in einwandfreiem Zustand ist und sich für den Bestimmungszweck eignet.
- Der Hersteller haftet nicht für Personen- oder Sachschäden, die durch die Nichtbeachtung der Montageanweisungen hervorgerufen werden. In diesen Fällen ist die Garantie für Materialfehler ausgeschlossen.
- Das Produkt vor jeder Maßnahme an der Anlage (Wartung, Reinigung) immer von der Stromversorgung trennen.
- Im Versorgungsnetz der Anlage eine Trennvorrichtung (als Option) mit

einem Kontaktöffnungsabstand vorsehen, die in den Bedingungen laut Überspannungskategorie III eine vollständige Trennung ermöglicht.

- Das Produkt bei der Installation vorsichtig handhaben und Quetschungen, Stöße, das Herabfallen und den Kontakt mit jeder Art von Flüssigkeit vermeiden. Das Produkt nicht in der Nähe von Wärmequellen positionieren und keinen offenen Flammen aussetzen. Die erwähnten Sachverhalte können das Produkt beschädigen bzw. Störungen oder Gefahrensituationen hervorrufen. In diesen Fällen die Installation unverzüglich abbrechen und den Kundendienst einschalten.

2 - PRODUKTBESCHREIBUNG UND BESTIMMUNGSZWECK

TTD0110 ist ein 1-10 Volt-Spannungsregler, der die Ausgangleistung der Netzgeräte mit dimmbarem Ausgang für die Regelung der Lichtquellen steuert. **Jeder andere Einsatz ist unsachgemäß und untersagt.** Das System ist mit einem Funkempfänger ausgerüstet, der mittels „Rolling-Code“ auf einer Frequenz von 433,92 MHz arbeitet. Es kann mit Nice-kompatiblen Produkten (**Tabelle 1**) und mit einer externen Taste verwaltet werden, mit der sich die Lampe ein- bzw. ausschalten lässt und die Helligkeit eingestellt werden kann.

TABELLE 1

Serie	Modell	Tasten	Programmierung	Funktionen
Nice Era	Era P	▲	Modus 1 (Kapitel 4)	Slider (Kapitel 4)
		■		
	Era W	▼		
	Era MiniWay			
	Era One	○	Modus 2 (Kapitel 4)	
	Era Inti			
NiceWay	NiceWay	▲	Modus 1 (Kapitel 4)	
Nice Ergo	Ergo	■		
		▼		
Nice Flor	Flor-m	○	Modus 2 (Kapitel 4)	
Nice Very	Very VR	▲	Modus 1 (Kapitel 4)	
		■		
		▼		

Nice Home	Touch HSTS2	Display	Modus 1 (Kapitel 4)	
	HSTX8	○	Modus 2 (Kapitel 4)	

3 - ELEKTRISCHE ANSCHLÜSSE

Spezifische Hinweise:

- **Dieses Produkt steht unter gefährlicher elektrischer Spannung. Deshalb dürfen die Öffnung des Gehäuses sowie sämtliche elektrischen Anschlüsse nur mit getrennter elektrischer Spannung vorgenommen werden.**
- **In keinem Fall das Antennenkabel durchschneiden, das unter gefährlicher elektrischer Spannung steht.**

Das Gerät TTD0110 für die Stromanschlüsse öffnen (**Abb. 1**) und gemäß den in **Abb. 2** und **3** gezeigten Anleitungen vorgehen (Beispiel für einen kompletten Stromanschluss):

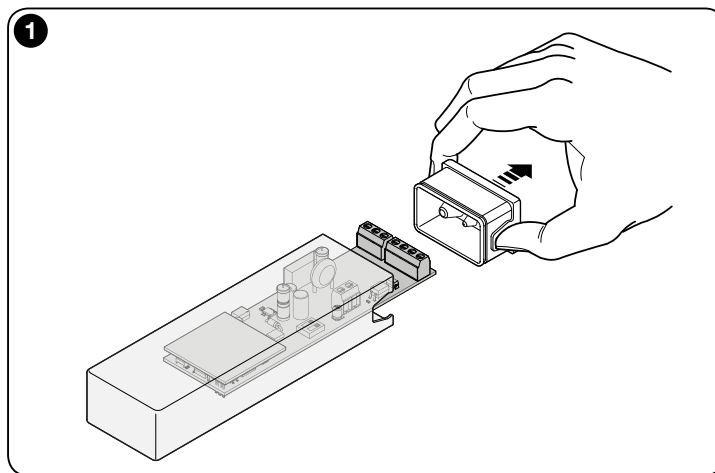

2

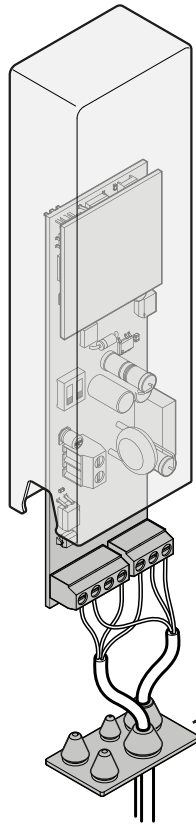

3

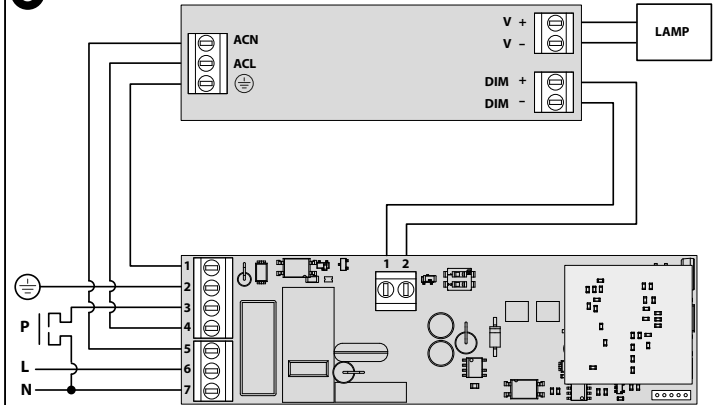

	Netzspannung	Klemmen
Eingang / Versorgung TTD0110	220 - 240 V AC	7 – Phase N 6 – Neutralleiter F 2 – Erdung T
Ausgang / Versorgung externer Treiber		5 – Phase N 4 – Neutralleiter F 1 – Erdung T
Ausgang / Externe Taste		3 – Taste P 7 – Neutralleiter N
	Niederspannung	Klemmen
Ausgang / Externer Treiber: Regelung 1-10 V oder 0-10 V oder 2-10 V oder PWM	Dimmer an Versorgung / Treiber angeschlossen	1 (-) 2 (+)

Das Produkt besitzt zwei Dip-Schalter (**Abb. 4**), mit denen sich die Belastungsart auswählen lässt, die am Ausgang angeschlossen wird:

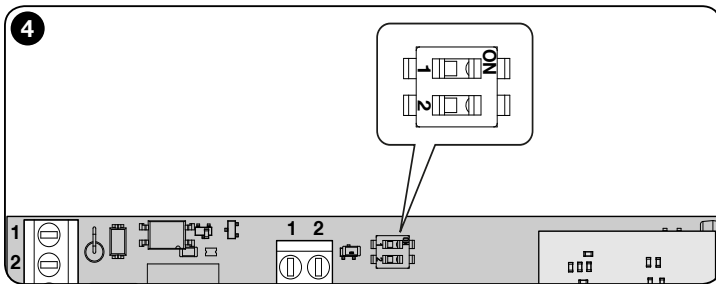

Dip 1	Dip 2	Beschreibung
Off	Off	Ausgang 2-10 V
On	Off	Ausgang 1-10 V
Off	On	Ausgang 0-10 V
On	On	PWM (1k Hz)

Hinweis: Die Belastungsart in den Angaben zu den technischen Eigenschaften des Geräts prüfen, das angeschlossen wird.

4 – PROGRAMMIERUNG

Die Programmierung des Geräts TTD0110 mit einem Sender vornehmen, der im „Modus 1“ gespeichert ist, oder mit der externen Taste.

Es ist möglich, bis zu 30 Sender im „**Modus 1**“ oder im „**Modus 2**“ zu speichern, um verschiedene Verhaltensweisen zu erzielen:

TABELLE 2	
Modus 1: Automatische Zuweisung der 3 Befehle an die drei Tasten des Senders	
Tasten	Funktion
 / ①	Dimmer Up
 / ②	Toggle

 / ③	Dimmer Down
④ ...	-

Modus 2: Freie Zuweisung eines verfügbaren Befehls

Funktion	Verfahren	Beschreibung
Dimmer Up	1 kurzes Drücken der Taste (< 1 Sekunde)	Die Helligkeit der Lampe erhöht sich um einen kleinen Anteil, sofern nicht bereits der Maximalwert eingestellt ist
	1 langes Drücken der Taste (> 1 Sekunde)	Die Helligkeit der Lampe erhöht sich, bis der eingestellte Maximalwert erreicht ist oder die Taste losgelassen wird
Toggle	Bei jedem Tastendruck	Der Dimmer aktiviert (On) oder deaktiviert (Off) die angeschlossene Lichtquelle. Helligkeitswert, der „On“ zugeordnet ist: die zuletzt im Dimmer gespeicherte Helligkeitsstufe. Der Dimmer speichert den Wert jeweils automatisch, wenn eine eingeschaltete Lampe ausgeschaltet wird (in diesem Fall entspricht der gespeicherte Wert der Helligkeit der Lampe vor dem Ausschalten) oder zirka 60 Sekunden nach der letzten Helligkeitsänderung (in diesem Fall wird der letzte Wert gespeichert).
		Dimmer Down

Dimmer Up Toggle Dimmer Down ...	Bei jedem Tastendruck	Die verschiedenen Funktionen werden wechselweise durchgeführt
---	----------------------------------	---

4.1 – Funktion „Slider“

Ermöglicht das Ein- / Ausschalten der Lampen und die dynamische Regelung der Helligkeit. Die kapazitive Oberfläche verhält sich wie ein Cursor (Slider):

Verfahren	Beschreibung
Kurzes Antippen des Sliders	Befehl für die absolute Positionierung
Wischgeste auf dem Slider	Abfolge von Befehlen für die dynamische Regelung der Helligkeit: Eingabe von Befehlen unabhängig von der Position des Fingers

4.2 – LED (Abb. 5)

Die LED auf der Rückseite des Geräts TTD0110 erzeugt verschiedene Signalisierungen – sowohl bei der Programmierung als auch den allgemeinen Meldungen:

Blinkintervalle	Farbe	Ausführung	Beschreibung
6	Grün	Am Ende des Speichervorgangs eines Senders	Speicher voll. Der Sender kann nicht gespeichert werden
2	Grün	Dimmer wird versorgt	Speicher leer (= kein Sender gespeichert)
2	Rot	Bei jedem Programmiervorgang	Es liegt ein Fehler vor
Eingeschaltet Dauerlicht	Blau	Eingeschaltet, wenn das Netzgerät / der Treiber aktiviert wird	Spannung Klemmen 5 und 4

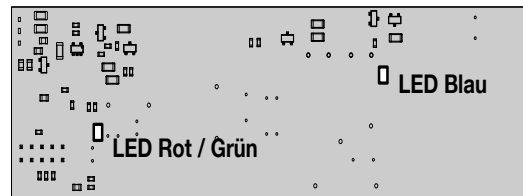

5



Diese Anleitung veranschaulicht die Programmierphasen mithilfe von Symbolen, deren Bedeutung in der folgenden Tabelle aufgeführt ist:

LEGENDE	
LED: Verhalten in den Programmierphasen	
Symbol	Beschreibung
	EINGESCHALTET
	AUSGESCHALTET
	LANGES Blinken
	KURZES Blinken
	SCHNELLES Blinken
Sonstige Symbole	
Symbol	Beschreibung
	SPANNUNG TRENNEN









	VERSORGEN
	LAMPE EIN
	LAMPE AUS
	GEWÜNSCHTER HELLIGKEITSWERT DER LAMPE
	KURZ DRÜCKEN
	TASTE DES SENDERS GEDRÜCKT HALTEN
	TASTE DES SENDERS LOSLASSEN
	DIE TASTE DES SENDERS GLEICHZEITIG GEDRÜCKT HALTEN
	DIE TASTE DES SENDERS GLEICHZEITIG LOSLASSEN
	TASTEN DES SENDERS
	TASTEN DES SENDERS
	DIE GEWÜNSCHTE TASTE DES SENDERS KURZ DRÜCKEN
	BEACHTEN / AUSWÄHLEN
	WARTEN BIS ...
 2 Sekunden	EINE GENAU FESTGELEGTE ZEIT ABWARTEN

	DIE EXTERNE TASTE KURZ DRÜCKEN
	DIE TASTE DES SENDERS GEDRÜCKT HALTEN
	DIE EXTERNE TASTE LOSLASSEN

4.3 – Selbstlernverfahren Sender









4.3.1 – Verwendung des „Ersten Senders“ (Leerer Speicher)

Mit diesem Vorgang kann dem Dimmer im „Modus 1“ ein Sender zugeordnet werden.

01.		 2 Sekunden		2  Grüne LED
02.	innerhalb von 5 Sekunden	  für 8 Sekunden		
03.	2  Grüne LED: Speicherung OK			
	2  Rote LED: Speicherung NICHT ABGESCHLOSSEN <i>In diesem Fall den ganzen Vorgang von Anfang an wiederholen</i>			



4.3.2 – Verwendung der „Weiteren Sender“: Modus 1













Mit diesem Vorgang kann dem Dimmer im „Modus 1“ ein Sender zugeordnet werden.









01.	NEU Sender	 für 8 Sekunden		1  Rote LED
02.	BISHERIGER Sender Bereits gespeichert		x 3 	
03.	NEU Sender	 für 5 Sekunden		
04.	2  Grüne LED: Speicherung OK			
	2  Rote LED: Speicherung NICHT ABGESCHLOSSEN <i>In diesem Fall den ganzen Vorgang von Anfang an wiederholen</i>			

4.3.3 – Verwendung der „Weiteren Sender“: Modus 2

Mit diesem Vorgang kann dem Dimmer im „Modus 2“ ein Sender zugeordnet werden.











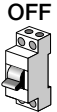





01.	BISHERIGER Sender bereits gespeichert	 für 8 Sekunden		1  Grüne LED
------------	--	---	---	--

02.	BISHERIGER Sender bereits gespeichert	 für 8 Sekunden		2  Grüne LED
03.	BISHERIGER Sender bereits gespeichert		 Die gewünschte Funktion auswählen:	
	Dimmer Up > Toggle > Dimmer Down			x 1 
	Dimmer Up			x 2 
	Dimmer Down			x 3 
	Toggle			x 4 
	Ebene 1			x 5 
	Ebene 2			x 6 
	Ebene 3			x 7 
	Ebene 4			x 8 
	OFF			x 9 

	ON	x 10 
04.	 5 Sekunden = 	...  Grüne LED ... Blinkintervalle gemäß gewählter Funktion
05.	 Gewünschte Taste des Senders	 Grüne LED  3 Sek. = 
06.	2  Grüne LED: Speicherung OK	

4.3.4 – Verwendung der „Externen Taste“: Modus 2

Mit diesem Vorgang kann dem Dimmer im „Modus 2“ ein Sender zugeordnet werden.

01.							3 Sek. = 	
02.		 Grüne LED		3 Sek. = 			beim 5. 	
03.	 Die gewünschte Funktion auswählen							
	Dimmer Up > Toggle > Dimmer Down						x 1 	

	Dimmer Up	x 2 
	Dimmer Down	x 3 
	Toggle	x 4 
	Ebene 1	x 5 
	Ebene 2	x 6 
	Ebene 3	x 7 
	Ebene 4	x 8 
	OFF	x 9 
	ON	x 10 
04.	 5 Sekunden	 Grüne LED ... Blinkintervalle gemäß gewählter Funktion
05.	 Gewünschte Taste des Senders	 Grüne LED  3 Sek. = 
06.	2  Grüne LED: Speicherung OK	

4.4 – Löschen des Speichers

4.4.1 – Verwendung des „Gespeicherten Senders“

Der Speicher kann anhand des Senders ganz oder teilweise gelöscht werden, der im „Modus 1“ gespeichert ist.

01.			1 Grüne LED	
02.			2 Grüne LED	
03.			3 Grüne LED	
04.			4 Grüne LED	
05.	Die gewünschte Funktion auswählen			
	Nur Sender löschen			
	Nur Parameter löschen			

	Nur Sender und Parameter löschen		
06.	5 Sekunden	2 Grüne LED	
2 Rote LED: Speicherung NICHT ABGESCHLOSSEN <i>In diesem Fall den ganzen Vorgang von Anfang an wiederholen</i>			

4.4.2 – Verwendung der „Externen Taste“

01.						
		Grüne LED	Grüne LED			
02.		Grüne LED				beim 2.
		Grüne LED				beim 5.
03.		Grüne LED				beim 5.
04.	Die gewünschte Funktion auswählen					

	Nur Sender löschen	x 1	
	Nur Parameter löschen	x 2	
	Nur Sender und Parameter löschen	x 3	
05.	5 Sekunden	Grüne LED ... Blinkintervalle gemäß gewählter Funktion	
06.		Grüne LED 3 Sek. =	
07.	2 Grüne LED: Speicherung OK		

4.5 – Programmierung der Helligkeitsstufen

4.5.1 – Verwendung des „Gespeicherten Senders“:

Dieser Vorgang kann nur mit Sendern ausgeführt werden, die bereits im „Modus 1“ gespeichert sind.

Die „gespeicherte Helligkeitsstufe kann nur aufgerufen werden, nachdem sie der Taste eines Senders zugeordnet wurde, der ihm Modus 2 programmiert wurde.

01.		3 Sek.	1 Grüne LED	
-----	--	--------	--------------	--

02.		3 Sek.	2 Grüne LED		
03.	Die Tasten ▲ - ▼ für die Einstellung der Helligkeit verwenden	 Wert der gewünschten Lichtstärke	10 Sekunden	2 Grüne LED	
04.	Die gewünschte Funktion auswählen				
	Ebene 1		=	2 Grüne LED	
	Ebene 2		=	2 Grüne LED	
	Ebene 3		=	2 Grüne LED	
	Ebene 4		=	2 Grüne LED	

4.5.2 – Verwendung der „Externen Taste“

01.						
			Grüne LED	3 Sek. = ■		
02.			Grüne Grün		3 Sek. = ■	
03.			Grüne Grün		3 Sek. = ■	beim 2.
04.	Die Lichtstärke der Lampe mit der externen Taste einstellen:					
	1. langes Drücken der externen Taste = erhöht die Helligkeit bis die Taste losgelassen wird					
	2. langes Drücken der externen Taste = reduziert die Helligkeit bis die Taste losgelassen wird					
	ACHTUNG! = Funktion „Toggle“ (ON/OFF)					
05.		Gewünschte Lichtstärke		= 2	+	5 Sekunden

06.		Gewünschte Ebene auswählen				
	Ebene 1	x 1				
	Ebene 2	x 2				
	Ebene 3	x 3				
	Ebene 4	x 4				
07.		5 Sekunden		Grüne LED +		... Blinkintervalle gemäß gewählter Funktion
08.			Grüne LED		3 Sek. = ■	
09.	2		Grüne LED: Speicherung OK			

4.6 – Programmierung der Sperrung und Entsperrung des Speichers

4.6.1 – Verwendung des „Gespeicherten Senders“:

Dieser Vorgang kann nur mit Sendern ausgeführt werden, die bereits im „Modus 1“ gespeichert sind.

01.			1		Grüne LED	
-----	--	--	----------	--	------------------	--

02.			2 Grüne LED	
03.			3 Grüne LED	
04.			4 Grüne LED	
05.	Die gewünschte Funktion auswählen			
	Speicher sperren		2 ;	
	Speicher entsperren		2 ;	

4.6.2 – Verwendung der „Externen Taste“

01.	OFF 		ON 		Grüne LED	3 Sek. =	
-----	---------	--	--------	--	-----------	----------	--

02.		Grüne LED	3 Sek. =		beim 2.
03.		Grüne LED	3 Sek. =		beim 2.
04.	Die gewünschte Funktion auswählen				
	Speicher sperren			x 1	
	Speicher entsperren			x 2	
05.	5 Sekunden	Grüne LED + ... Blinkintervalle gemäß gewählter Funktion			
06.		Grüne LED	3 Sek. =		
07.	2 Grüne LED: Speicherung OK				

5 – Ersatz von Sicherungen

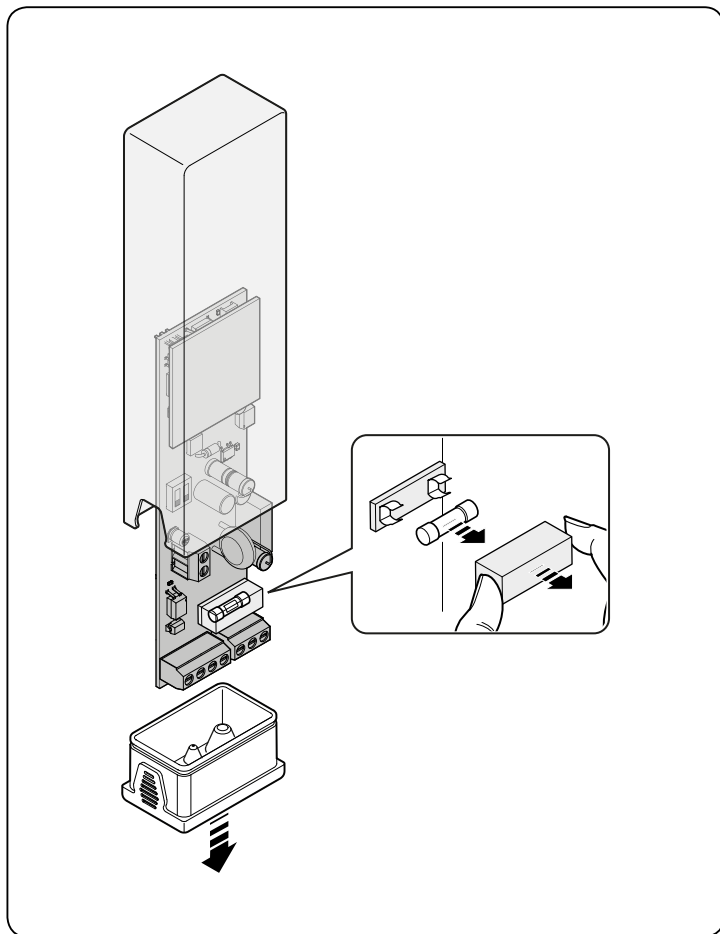

6 – TECHNISCHE MERKMALE

Input	
Spannung	230 V AC ± 10 %
Frequenz	50 Hz
Leistungsaufnahme (Stand-by)	550 mW
Output	
Spannung	230 V AC ± 10 %
Frequenz	50 Hz
Maximaler Anzugsstrom	80 A
Umwelt	
Betriebstemperatur	-40 + 55 °C
Lagertemperatur	-40 + 70 °C
IP	54
Abmessungen	43 x 25 x 150 mm
Gewicht	100 g

7 - ENTSORGUNG DES PRODUKTES

Der Ausbau dieses Produkts am Ende der Lebensdauer muss genauso wie seine Installation von Fachpersonal ausgeführt werden. Dieses Produkt ist aus verschiedenen Materialien gebaut. Einige davon können recycelt werden, andere müssen hingegen entsorgt werden. Informieren Sie sich über die von den lokalen Verordnungen vorgesehenen Recyclings- oder Entsorgungssysteme für diese Produktkategorie.

Achtung! – Bestimmte Teile des Produktes können Schadstoffe oder gefährliche Substanzen enthalten, die – falls sie in die Umwelt gelangen – schädliche Auswirkungen auf das Ökosystem und die menschliche Gesundheit haben könnten.



Wie durch das nebenstehende Symbol veranschaulicht, ist es verboten, dieses Produkt zum Haushaltsmüll zu geben. Es muss entsprechend den örtlichen Bestimmungen entsorgt werden oder dem Verkäufer beim Kauf eines neuen, gleichwertigen Produktes zurückgegeben werden.

Achtung! – Die örtlichen Verordnungen können schwere Strafen im Fall einer widerrechtlichen Entsorgung dieses Produktes vorsehen. Das Verpackungsmaterial des Produktes muss in Übereinstimmung mit den örtlichen Vorschriften entsorgt werden.

SPIS TREŚCI

1	OGÓLNE ZALECENIA	1
2	OPIS URZĄDZENIA I JEGO PRZEZNACZENIE	2
3	POŁĄCZENIA ELEKTRYCZNE	2
4	PROGRAMOWANIE	4
4.1	Funkcja „Slider”	5
4.2	Dioda	5
4.3	Procedura wczytywania nadajników	6
4.3.1	Użycie „Pierwszego nadajnika” (Pusta pamięć)	6
4.3.2	Użycie „Dodatkowych nadajników”: Tryb 1	7
4.3.3	Użycie „Dodatkowych nadajników”: Tryb 2	7
4.3.4	Użycie „Przycisku zewnętrznego”: Tryb 2	8
4.4	Kasowanie pamięci	9
4.4.1	Użycie „Nadajnika wczytanego”	9
4.4.2	Użycie „Przycisku zewnętrznego”	9
4.5	Programowanie poziomów oświetlenia	10
4.5.1	Użycie „Nadajnika wczytanego”	10
4.5.2	Użycie „Przycisku zewnętrznego”	11
4.6	Programowanie blokowania i odblokowywania pamięci	11
4.6.1	Użycie „Nadajnika wczytanego”	11
4.6.2	Użycie „Przycisku zewnętrznego”	12
5	Wymiana bezpiecznika	13
6	PARAMETRY TECHNICZNE	13
7	UTYLIZACJA PRODUKTU	13

1 - OGÓLNE ZALECENIA

- **ZALECENIE: Ważne instrukcje bezpieczeństwa. Należy przestrzegać wszystkich instrukcji, ponieważ nieprawidłowy montaż może być przyczyną poważnych szkód.**
- **UWAGA: Ważne instrukcje bezpieczeństwa. W celu zapewnienia bezpieczeństwa osób, należy przestrzegać niniejszych instrukcji. Należy zachować niniejszą instrukcję.**
- Nie zezwalać dzieciom na zabawę urządzeniem.
- Nie zezwalać dzieciom na zabawę urządzeniami sterującymi produktem. Przechowywać piloty w miejscu niedostępnym dla dzieci.
- Często sprawdzać urządzenie, w szczególności sprawdzać kable, oznaki zużycia lub uszkodzenia. Nie używać w razie konieczności naprawy lub regulacji, ponieważ istnienie usterki może prowadzić do poważnych obrażeń podczas montażu.
- Czyszczenie i konserwacja, za którą jest odpowiedzialny użytkownik, nie powinna być wykonywana przez dzieci pozbawione opieki.
- **UWAGA:** w celu uniknięcia wszelkiego zagrożenia na skutek przypadkowego uzbrojenia termicznego urządzenia odłączającego, nie należy zasilać tego urządzenia przy użyciu zewnętrznego urządzenia, jak zegar lub podłączać go do obwodu charakteryzującego się regularnym podłączaniem lub odłączaniem zasilania.
- Przed rozpoczęciem montażu należy sprawdzić informacje na temat „Parametrów technicznych produktu”) (zawartych w niniejszej instrukcji). Jeżeli produkt nie jest odpowiedni, NIE należy wykonywać montażu.
- Materiał opakowaniowy podlega utylizacji zgodnie z lokalnymi przepisami.
- Przed przystąpieniem do montażu produktu, sprawdzić, czy wszystkie elementy i materiały przeznaczone do użycia są w idealnym stanie i są odpowiednie do użycia.
- Producent nie ponosi odpowiedzialności za szkody materialne lub osobowe spowodowane w wyniku nieprzestrzegania instrukcji montażu. W takich przypadkach, nie ma zastosowania rękojmia za wady materialne.
- Przed wykonaniem działań na instalacji (konserwacja, czyszczenie), należy zawsze odłączyć produkt od sieci zasilającej.
- W sieci zasilania instalacji należy przygotować urządzenie odłączające (nieznajdujące się na wyposażeniu), którego odległość pomiędzy stykami podczas otwarcia zapewnia całkowite odłączenie w warunkach określonych przez III kategorię przepięciową.

- Podczas montażu należy się delikatnie obchodzić z urządzeniem, chroniąc je przed zgnieceniem, uderzeniem, upadkiem lub kontaktem z jakiegokolwiek rodzaju płynami. Nie umieszczać urządzenia w pobliżu źródeł ciepła i nie wystawiać go na działanie otwartego ognia. Opisane sytuacje mogą doprowadzić do uszkodzenia urządzenia, być przyczyną nieprawidłowego działania lub spowodować zagrożenia. Jeżeli doszłoby do którejś z opisanych sytuacji, należy natychmiast przerwać montaż i zwrócić się o pomoc do Serwisu Technicznego.

2 - OPIS PRODUKTU I JEGO PRZEZNACZENIE

TTD0110 jest regulatorem napięcia 1-10 Volt, który pilotuje wyjście mocy zasilaczy/sterowników do regulacji źródeł światła. **Każde inne zastosowanie jest niewłaściwe i zabronione.**

Posiada odbiornik radiowy, działający w częstotliwości 433.92 MHz, z kodowaniem typu „rolling code”.

Może być sterowany przy użyciu kompatybilnych produktów Nice (Tabela 1) i przy użyciu przycisku zewnętrznego, przy użyciu którego będzie można włączać, wyłączać i regulować natężenie światła lampy.

TABELA 1

Seria	Model	Przyciski	Programowanie	Funkcje
Nice Era	Era P	▲	Tryb 1 (rozdział 4)	Slider (rozdział 4)
	Era W	■		
	Era MiniWay	▼		
	Era One	○	Tryb 2 (rozdział 4)	
	Era Inti			
NiceWay	NiceWay	▲	Tryb 1 (rozdział 4)	
Nice Ergo	Ergo	■		
		▼		
Nice Flor	Flor-m	○	Tryb 2 (rozdział 4)	
Nice Very	Very VR	▲	Tryb 1 (rozdział 4)	
		■		
		▼		

Nice Home	Touch HSTS2	wyświetlacz	Tryb 1 (rozdział 4)	
	HSTX8	○	Tryb 2 (rozdział 4)	

3 - POŁĄCZENIA ELEKTRYCZNE

Specjalne zalecenia:

- Produkt jest podłączony do niebezpiecznego napięcia elektrycznego: otwieranie pojemnika oraz wykonywanie wszystkich połączeń musi się odbywać przy odłączonym zasilaniu elektrycznym.
- Nigdy, z żadnego powodu, nie przecinać kabla anteny, przez który przepływa niebezpieczne napięcie elektryczne.

W celu wykonania połączeń elektrycznych należy otworzyć TTD0110 (rys. 1) i następnie postępować w sposób przedstawiony na rys. 2 i 3 (przykład kompletnego połączenia elektrycznego):

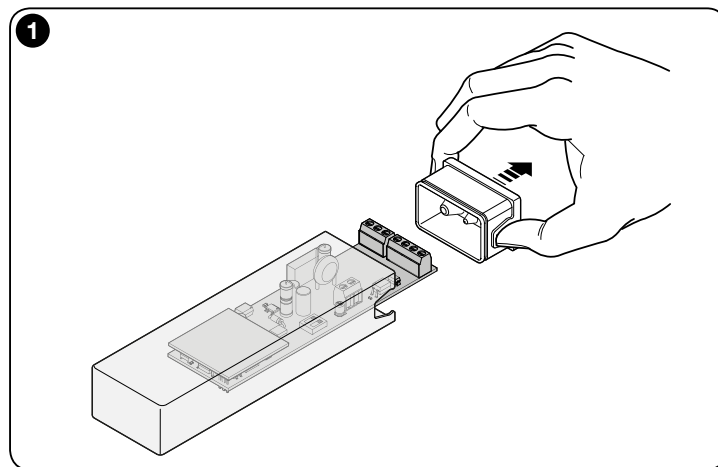

2

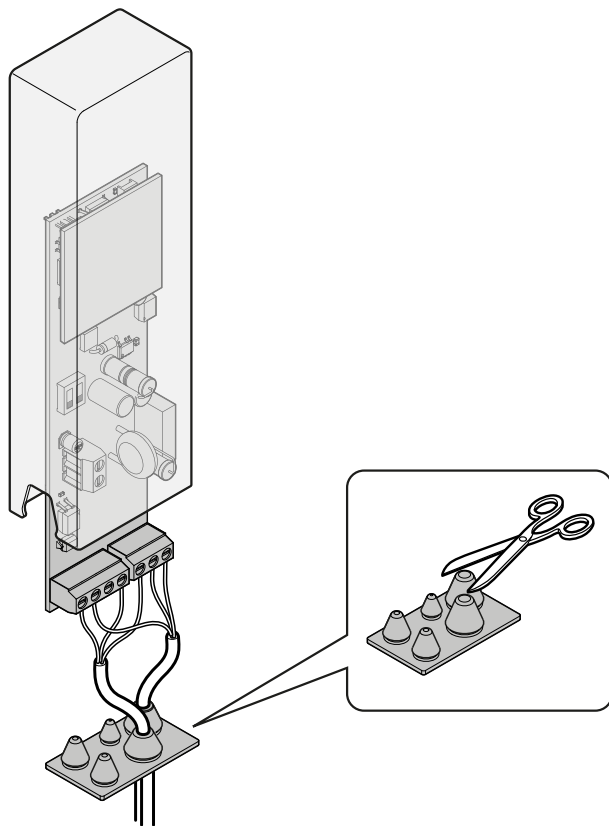

3

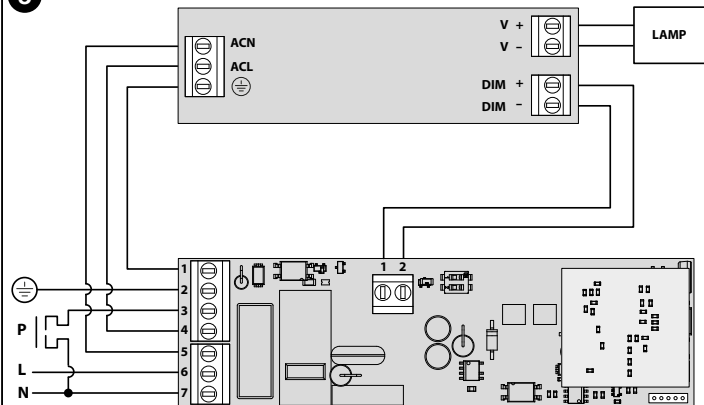

	napięcie sieciowe	zaciski
Wejście / Zasilanie TTD0110	220 - 240 Vac	7 - faza N 6 - neutralny F 2 - uziemienie T
Wyjście / Zasilanie sterownika zewnętrznego		5 - faza N 4 - neutralny F 1 - uziemienie T
Wyjście / Przycisk zewnętrzny		3 - przycisk P 7 - neutralny N
	niskie napięcie	zaciski
Wyjście / Sterownik zewnętrzny: regulacja 1-10 V lub 0-10 V lub 2-10 V lub PWM	regulator światła podłączony do zasilacza/sterownika	1 (-) 2 (+)

Produkt posiada dwa przełączniki dip-switch (**rys. 4**) umożliwiające wybór rodzaju ładunku podłączonego do wyjścia:

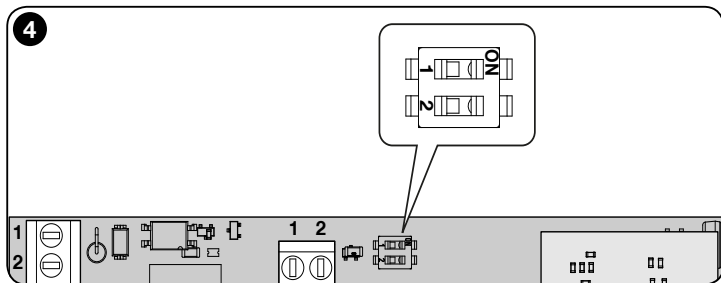

Dip 1	Dip 2	Opis
Off	Off	Wyjście 2-10 V
On	Off	Wyjście 1-10 V
Off	On	Wyjście 0-10 V
On	On	PWM (1k Hz)

Uwaga: sprawdzić rodzaj zasilania w parametrach technicznych podłączonego urządzenia.



4 - PROGRAMOWANIE

Programowanie TTD0110 musi być wykonane przy użyciu nadajnika wczytanego w „Trybie 1” lub przycisku zewnętrznego.

W celu uzyskania różnych zachowań, możliwe jest wczytanie do 30 nadajników w „Trybie 1” lub w „Trybie 2” :

TABELA 2

Tryb 1 : przypisać automatycznie trzy polecenia do pierwszych trzech przycisków nadajnika

Przyciski	Funkcja
 / ①	Regulator światła Góra
 / ②	Toggle
 / ③	Regulator światła Dół

④

...

-

Tryb 2 : przypisać dowolne polecenie spośród dostępnych poleceń

Funkcja	Procedura	Opis
Regulator światła Góra	1 krótkotrwałe naciśnięcie przycisku (< 1 sekunda)	jeżeli lampa nie jest już ustawiona na wartości maksymalnej, powoduje nieznaczne zwiększenie oświetlenia
	1 przedłużone naciśnięcie przycisku (> 1 sekunda)	powoduje zwiększenie oświetlenia, aż do osiągnięcia maksymalnej ustawionej wartości lub zwolnienia przycisku
Toggle	każdorazowe naciśnięcie przycisku	regulator światła włącza (On) lub wyłącza (Off) podłączone źródło światła. Wartość oświetlenia podłączonego do „On”: ostatni próg oświetlenia zapamiętany w regulatorze światła. Wartość jest zapamiętywana automatycznie przez regulator światła, gdy lampa przechodzi w stan od zaświeconej do zgaszonej (w tym przypadku wczytana wartość będzie równa oświetleniu lampy przed jej zgaszeniem) lub, w którymkolwiek przypadku, po około 60 sekundach od ostatniej zmiany oświetlenia (w tym przypadku zostanie zapamiętana ostatnia wartość).
Regulator światła Dół	1 krótkotrwałe naciśnięcie przycisku (< 1 sekunda)	jeżeli lampa nie jest już ustawiona na wartości minimalnej, powoduje nieznaczne zmniejszenie oświetlenia
	1 przedłużone naciśnięcie przycisku (> 1 sekunda)	powoduje zmniejszenie oświetlenia, aż do osiągnięcia minimalnej ustawionej wartości lub zwolnienia przycisku

Regulator światła Góra Toggle Regulator światła Dół ...	każdorazowe naciśnięcie przycisku	różne funkcje zostaną wykonane w trybie przemiennym
--	-----------------------------------	---

4.1 - Funkcja „Slider”

Umożliwia włączanie / wyłączenie lamp i regulację dynamiczną oświetlenia. Powierzchnia zachowuje się jak suwak (slider):

Procedura	Opis
krótkotrwałe dotknięcie suwaka	polecenie pozycjonowania absolutnego suwaka
przesunięcie na suwaku	lista poleceń w celu wyregulowania oświetlenia lampy w sposób dynamiczny: przesłanie poleceń niezależnie od położenia palca.

4.2 - Dioda (rys. 5)

Dioda znajdująca się w dolnej części TTD0110 emituje różne sygnały zarówno w procedurach programowania, jak również sygnały ogólne:

Mignięcia	Kolor	Działanie	Opis
6	zielony	po zakończeniu procedury wczytywania nadajnika	pamięć jest pełna i wczytanie nadajnika nie jest możliwe
2	zielony	gdy jest zasilony regulator światła	jego pamięć jest pusta (= brak wczytanego nadajnika)
2	czerwony	podczas każdej procedury programowania	popelniono błąd
zaświecona stała	niebieski	jej zaświecenie następuje po włączeniu zasilacza / sterownika	Napięcie zacisków 5 i 4

5





W niniejszej instrukcji, procedury programowania zostały wyjaśnione przy użyciu ikon, a ich znaczenie zostało opisane w poniższej tabeli:

LEGENDA	
DIODA: zachowanie podczas procedur programowania	
Symbol	Opis
	ZAŚWIECONA
	ZGASZONA
	miganie DŁUGIE
	miganie KRÓTKIE
	miganie SZYBKIE
inne symbole	
Symbol	Opis
	ODŁĄCZYĆ ZASILANIE

PL

	PODŁĄCZYĆ ZASILANIE
	LAMPA ZAŚWIECONA
	LAMPA ZGASZONA
	WYMAGANA WARTOŚĆ OŚWIETLENIA LAMPY
	NA KRÓTKO NACISNĄĆ
	PRZYTRZYMAĆ WCIŚNIĘTY PRZYCISK NADAJNIKA
	ZWOLNIĆ PRZYCISK NADAJNIKA
	PRZYTRZYMAĆ RÓWNOCZEŚNIE WCIŚNIĘTY PRZYCISK NADAJNIKA
	ZWOLNIĆ RÓWNOCZEŚNIE PRZYCISK NADAJNIKA
	PRZYCISKI NADAJNIKA
	PRZYCISKI NADAJNIKA
	NA KRÓTKO NACISNĄĆ ŻĄDANY PRZYCISK NADAJNIKA
	OBSERWOWAĆ / WYBRAĆ
	ODCZEKAĆ, AŻ ...
	ODCZEKAĆ OKREŚLONĄ ILOŚĆ CZASU

	NA KRÓTKO NACISNĄĆ PRZYCISK ZEWNĘTRZNY
	PRZYTRZYMAĆ WCIŚNIĘTY PRZYCISK ZEWNĘTRZNY
	ZWOLNIĆ PRZYCISK ZEWNĘTRZNY

4.3 - Procedura wczytywania nadajników

4.3.1 - Użycie „Pierwszego nadajnika” (Pusta pamięć)

Ta procedura umożliwi przypisanie nadajnika do regulatora światła w „Trybie I”.

01.	 OFF	 2 sekundy	 ON	2  zielona dioda
02.	w ciągu 5 sekund	  przez 8 sekund		
03.	2  zielona dioda: wczytywanie OK			
	2  czerwona dioda: wczytywanie NIEWYKONANE w tej sytuacji, powtórzyć procedurę od początku			



4.3.2 - Użycie „Dodatkowych nadajników”: Tryb 1













Ta procedura umożliwi przypisanie nadajnika do regulatora światła w „Trybie 1”.

01.	NOWY nadajnik	 przez 8 sekund		1  czerwona dioda
02.	STARY nadajnik <u>uprzednio wczytany</u>		x 3 	
03.	NOWY nadajnik	 przez 5 sekund		
04.	2  zielona dioda: wczytywanie OK			
	2  czerwona dioda: wczytywanie NIEWYKONANE w tej sytuacji, powtórzyć procedurę od początku			

4.3.3 - Użycie „Dodatkowych nadajników”: Tryb 2

Ta procedura umożliwi przypisanie nadajnika do regulatora światła w „Trybie 2”.

01.	STARY nadajnik <u>uprzednio wczytany</u>	 przez 8 sekund		1  zielona dioda
-----	--	---	--	--

02.	STARY nadajnik <u>uprzednio wczytany</u>	 przez 8 sekund		2  zielona dioda
03.	STARY nadajnik <u>uprzednio wczytany</u>		 wybrać żadaną funkcję:	
	Regulator światła Góra > Toggle > Regulator światła Dół			x 1 
	Regulator światła Góra			x 2 
	Regulator światła Dół			x 3 
	Toggle			x 4 
	Poziom 1			x 5 
	Poziom 2			x 6 
	Poziom 3			x 7 
	Poziom 4			x 8 
	OFF			x 9 

	ON	x 10
04.	5 sekund =	... zielona dioda !... mignięć w zależności od wybranej funkcji
05.	żądany przycisk nadajnika	zielona dioda 3 sek. =
06.	2 zielona dioda: wczytywanie OK	

4.3.4 - Użycie „Przycisku zewnętrznego”: Tryb 2

Ta procedura umożliwi przypisanie nadajnika do regulatora światła w „Trybie 2”.

01.	OFF	ON		zielona dioda	3 sek. =	
02.		dioda zielona	3 sek. =		po 5°	
03.	wybrać żądaną funkcję					



















	Regulator światła Góra > Toggle > Regulator światła Dół	x 1
	Regulator światła Góra	x 2
	Regulator światła Dół	x 3
	Toggle	x 4
	Poziom 1	x 5
	Poziom 2	x 6
	Poziom 3	x 7
	Poziom 4	x 8
	OFF	x 9
	ON	x 10
04.	5 sekund	zielona dioda !... mignięć w zależności od wybranej funkcji
05.	żądany przycisk nadajnika	zielona dioda 3 sek. =





06. 2  zielona dioda: wczytywanie OK

4.4 - Kasowanie pamięci











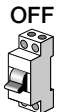











4.4.1 - Użycie „Nadajnika wczytanego”











Przy użyciu nadajnika wczytanego w „Trybie 1” można całkowicie lub częściowo skasować pamięć.

01.			1  zielona dioda	
02.			2  zielona dioda	
03.			3  zielona dioda	
04.			4  zielona dioda	
05.	 wybrać żadaną funkcję			
	Skasować wyłącznie nadajniki			

	Skasować wyłącznie parametry		
	Skasować wyłącznie nadajniki i parametry		
06.	 5 sekund	2  zielona dioda	
	2  czerwona dioda: wczytywanie NIEWYKONANE w tej sytuacji, powtórzyć procedurę od początku		

4.4.2 - Użycie „Przycisku zewnętrznego”

01.							3 sek. = 	
02.				3 sek. = 			po 2° 	
03.				3 sek. = 			po 5° 	





03.	 wybrać żądaną funkcję		
	Skasować wyłącznik nadajniki	x 1	
	Skasować wyłącznik parametry	x 2	
	Skasować wyłącznik nadajniki i parametry	x 3	
04.	 5 sekund	 zielona dioda I... mignięć w zależności od wybranej funkcji	
05.		 zielona dioda	 3 sek. = 
06.	2  zielona dioda: wczytywanie OK		

























4.5 - Programowanie poziomów oświetlenia

4.5.1 - Użycie „Nadajnika wczytanego”

Ta procedura może być wykonana wyłącznie z uprzednio wczytanym nadajnikiem w „Trybie 1”.

Wczytany poziom oświetlenia będzie możliwy do przywołania wyłącznie po przypisaniu go do przycisku nadajnika zaprogramowanego w Trybie 2.

01.		 3 sek.	1  zielona dioda	
------------	--	--	---	--

02.		 3 sek.	2  zielona dioda	
03.	Używać przycisków ▲ - ▼ do regulacji oświetlenia	 wartość wymaganego natężenia światła	 10 sekund	2  zielona dioda
04.	 wybrać żądaną funkcję			
	Poziom 1		 = 	2  zielona dioda
	Poziom 2		 = 	2  zielona dioda
	Poziom 3		 = 	2  zielona dioda
	Poziom 4		 = 	2  zielona dioda

4.5.2 - Użycie „Przycisku zewnętrznego”

01.						
			zielona dioda	3 sek. = ■		
02.						
		dioda zielony	3 sek. = ■			
03.						
		dioda zielony	3 sek. = ■		po 2°	
04.	Wyregulować oświetlenie lampy na żądaną wartość przy użyciu zewnętrznego przycisku:					
	1^ przedłużone naciśnięcie przycisku zewnętrznego = zwiększenie oświetlenia aż do zwolnienia przycisku					
	2^ przedłużone naciśnięcie przycisku zewnętrznego = zmniejszenie oświetlenia aż do zwolnienia przycisku					
	UWAGA! = funkcja „Toggle” (ON/OFF)					
05.			= 2 +		5 sekund	
	wartość wymaganego natężenia światła					

06.		wybrać żądany poziom				
	Poziom 1	x 1				
	Poziom 2	x 2				
	Poziom 3	x 3				
	Poziom 4	x 4				
07.		5 sekund		zielona dioda +	!... mignięć w zależności od wybranego poziomu	
08.			zielona dioda		3 sek. = ■	
09.	2	zielona dioda: wczytywanie OK				

4.6 - Programowanie blokowania i odblokowywania pamięci

4.6.1 - Użycie „Nadajnika wczytanego”

Ta procedura może być wykonana wyłącznie z uprzednio wczytanym nadajnikiem w „Trybie 1”.

01.			1	zielona dioda	

02.			2 zielona dioda	
03.			3 zielona dioda	
04.			4 zielona dioda	
05.	wybrać żądaną funkcję			
	Zablokować pamięć		2 ;	
	Odblokować pamięć		2 ;	

4.6.2 - Użycie „Przycisku zewnętrznego”

01.	OFF 		ON 			3 sek. =	
-----	---------	--	--------	--	--	----------	--

02.		zielona dioda 		3 sek. =			po 2°
03.		zielona dioda 		3 sek. =			po 2°
04.	wybrać żądaną funkcję						
	Zablokować pamięć					x 1	
	Odblokować pamięć					x 2	
05.	5 sekund		zielona dioda + !... mignięć w zależności od wybranej funkcji				
06.		zielona dioda 		3 sek. =			
07.	2 zielona dioda: wczytywanie OK						

5 - Wymiana bezpiecznika

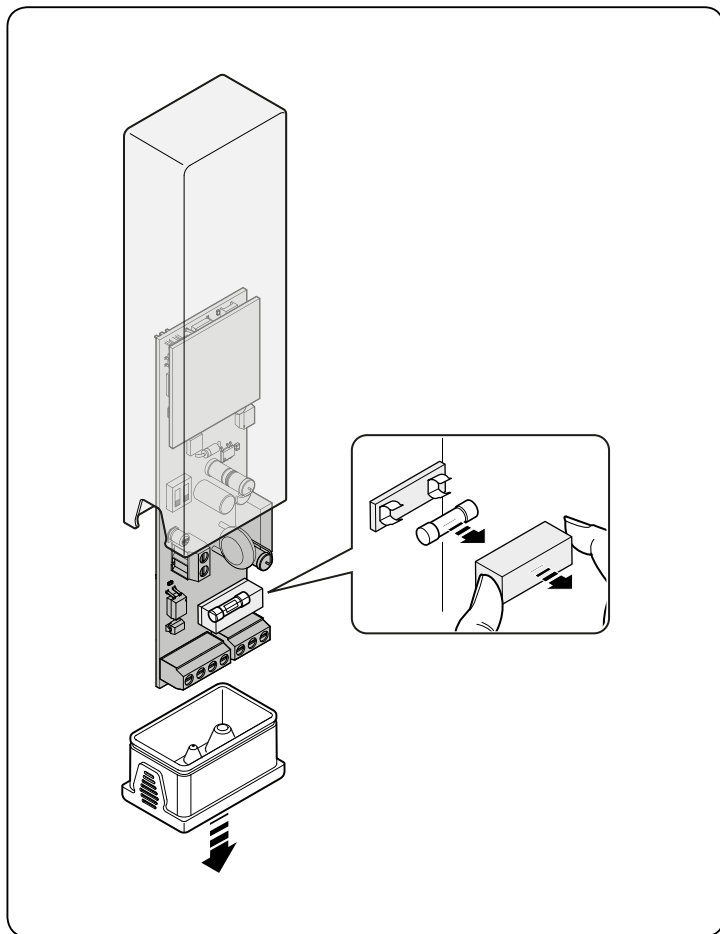

6 - PARAMETRY TECHNICZNE

Wejście	
Napięcie	230Vac ±10%
Częstotliwość	50 Hz
Pobór mocy (stand-by)	550 mW
Wyjście	
Napięcie	230Vac ±10%
Częstotliwość	50 Hz
Maksymalny prąd startowy	80 A
Środowisko	
Temperatura robocza	-40 + 55° C
Temperatura przechowywania	-40 + 70° C
IP	54
Wymiary	43 x 25 x 150 mm
Masa	100 g

7 - UTYLIZACJA PRODUKTU

Tak, jak w przypadku instalacji, również po upływie okresu użytkowania tego produktu czynności demontażowe powinien wykonywać wykwalifikowany personel. Urządzenie składa się z różnego rodzaju materiałów: niektóre z nich mogą zostać poddane recyklingowi, inne powinny zostać poddane utylizacji. Należy we własnym zakresie zapoznać się z informacjami na temat recyklingu i utylizacji, przewidzianymi w lokalnie obowiązujących przepisach dla danej kategorii produktu.

Uwaga! – niektóre elementy produktu mogą zawierać substancje szkodliwe lub niebezpieczne, które pozostawione w środowisku mogłyby zaszkodzić środowisku lub zdrowiu ludzkiemu.



Jak wskazuje symbol obok, zabrania się wyrzucania niniejszego produktu razem z odpadami domowymi. W celu usunięcia produktu należy zatem przeprowadzić zgodnie z lokalnie obowiązującymi przepisami „zbiórkę selektywną” lub zwrócić produkt do sprzedawcy w chwili zakupu nowego, równoważnego produktu.

Uwaga! – lokalne przepisy mogą przewidywać poważne kary w przypadku nielegalnego usunięcia niniejszego produktu. Opakowanie urządzenia należy utylizować zgodnie z lokalnymi przepisami.

INHOUDSOPGAVE

1	ALGEMENE AANBEVELINGEN	1
2	BESCHRIJVING VAN HET PRODUCT EN GEBRUIKSBESTEMMING	2
3	ELEKTRISCHE AANSLUITINGEN	2
4	PROGRAMMERING	4
4.1	Functie "Slider"	5
4.2	LED	5
4.3	Leerprocedure Zenders	6
4.3.1	Gebruik "Eerste zender" (geheugen leeg)	6
4.3.2	Gebruik "Overige zenders": Procedure 1	7
4.3.3	Gebruik "Overige zenders": Procedure 2	7
4.3.4	Gebruik "Externe knop": Procedure 2	8
4.4	Wissen van het geheugen	9
4.4.1	Gebruik "Opgeslagen zender"	9
4.4.2	Gebruik "Externe knop"	9
4.5	Programmering lichtsterkteniveaus	10
4.5.1	Gebruik "Opgeslagen zender"	10
4.5.2	Gebruik "Externe knop"	11
4.6	Programmering blokkering en deblokkering van het geheugen	12
4.6.1	Gebruik "Opgeslagen zender"	12
4.6.2	Gebruik "Externe knop"	12
5	Vervangen van de batterijen	13
6	TECHNISCHE KENMERKEN	14
7	AFDANKING VAN HET PRODUCT	14

1 - ALGEMENE AANBEVELINGEN

- **WAARSCHUWING: Belangrijke aanwijzingen voor de veiligheid. Leef alle voorschriften na, want een niet correct uitgevoerde installatie kan ernstige schade veroorzaken.**
- **LET OP! Belangrijke veiligheidsinstructies. Het is belangrijk dat deze instructies worden opgevolgd voor de veiligheid van personen. Bewaar deze instructies.**
- Kinderen mogen niet met het apparaat spelen.
- Laat kinderen niet met de bedieningsinrichtingen van het product spelen. Houd de afstandsbedieningen buiten het bereik van kinderen.
- Controleer de installatie regelmatig, in het bijzonder de kabels, tekenen van slijtage of schade. Gebruik het apparaat nooit als het hersteld of opnieuw afgesteld moet worden; een storing in de installatie kan immers tot letsels leiden.
- Reinigings- en onderhoudswerkzaamheden die door de gebruiker kunnen worden uitgevoerd, mogen niet worden toevertrouwd aan kinderen die niet onder toezicht staan.
- **LET OP!** Om ieder risico op onvoorziën heropstarten van het thermisch onderbrekingsmechanisme te vermijden, mag dit apparaat niet worden gevoed via een externe regelaar zoals een timer, noch worden aangesloten op een circuit dat regelmatig wordt in- of uitgeschakeld.
- Voordat u met de installatie begint, dient u de "Technische kenmerken van het product" te controleren (in dit handboek). Als het product niet geschikt is, mag u NIET overgaan tot de installatie.
- Het verpakkingsmateriaal van het product moet conform de plaatselijke verordeningen worden afgedankt.
- Voordat u met de installatie van het product doorgaat, dient u te controleren of al het te gebruiken materiaal in optimale staat en geschikt voor gebruik is.
- De fabrikant is niet aansprakelijk voor materiële schade, zowel aan personen als aan voorwerpen, die voortvloeit uit de niet-naleving van de montagevoorschriften. In die gevallen is enige garantie voor materiaalfouten uitgesloten.
- Voordat u enige activiteit aan de installatie onderneemt (onderhoud, reiniging), moet het product altijd van het stroomnet worden losgekoppeld.
- U moet op het spanningsnet van de installatie een uitschakelapparaat aansluiten (niet meegeleverd) met een openingsafstand voor de contacten waarbij volledige uitschakeling mogelijk is bij de condities

die gelden voor overspanningscategorie III.

- Behandel het product tijdens de installatie met zorg en voorkom dat het wordt geplet, dat er tegen wordt gestoten, dat het valt of dat het in aanraking komt met eender welke vloeistoffen. Zet het product niet in de buurt van warmtebronnen en stel het niet bloot aan open vuur. Hierdoor kan het beschadigd worden, waardoor storingen of gevaarlijke situaties kunnen ontstaan. Als dit gebeurt, stopt u de installatie onmiddellijk en wendt u zich tot de klantendienst.

2 - BESCHRIJVING VAN HET PRODUCT EN GBRUIKSBESTEMMING

De TTD0110 is een spanningsregelaar van 1-10 Volt die de vermogensuitgang van voedingen/drivers stuurt met het oog op de regeling van de lichtbronnen. **Ieder ander gebruik is oneigenlijk en verboden.** Hij is uitgerust met een RF-ontvanger die op de frequentie 433.92 MHz en met "rolling code"-codering werkt.

Hij kan worden bestuurd met de compatibele Nice-producten (**Tabel 1**) en met een externe knop waarmee de lichtsterkte van de lamp kan worden ingeschakeld, uitgeschakeld en ingesteld.

TABEL 1

Serie	Model	Toetsen	Programmering	Functionaliteit
Nice Era	Era P	▲	Procedure 1 (hoofdstuk 4)	Slider (hoofdstuk 4)
		■		
	Era W	▼		
	Era MiniWay			
	Era One	○	Procedure 2 (hoofdstuk 4)	
	Era Inti			
NiceWay	NiceWay	▲	Procedure 1 (hoofdstuk 4)	
Nice Ergo	Ergo	■		
		▼		
Nice Flor	Flor-m	○	Procedure 2 (hoofdstuk 4)	
Nice Very	Very VR	▲	Procedure 1 (hoofdstuk 4)	
		■		
		▼		

Nice Home	Touch HSTS2	display	Procedure 1 (hoofdstuk 4)	
	HSTX8	○	Procedure 2 (hoofdstuk 4)	

3 - ELEKTRISCHE AANSLUITINGEN

Speciale aanwijzingen:

- Het product staat onder gevaarlijke elektrische spanning: het openen van de houder en alle elektrische aansluitingen moeten gebeuren wanneer de elektrische spanning is uitgeschakeld.**
- Snijd onder geen enkele omstandigheid in de kabel van de antenne: deze staat onder gevaarlijke elektrische spanning.**

Om de elektrische aansluitingen te kunnen realiseren, moet de TTD0110 worden geopend (**afb. 1**); daarna dient u te werk te gaan zoals aangegeven in de **afb. 2** en **3** (voorbeeld van volledige elektrische aansluiting):

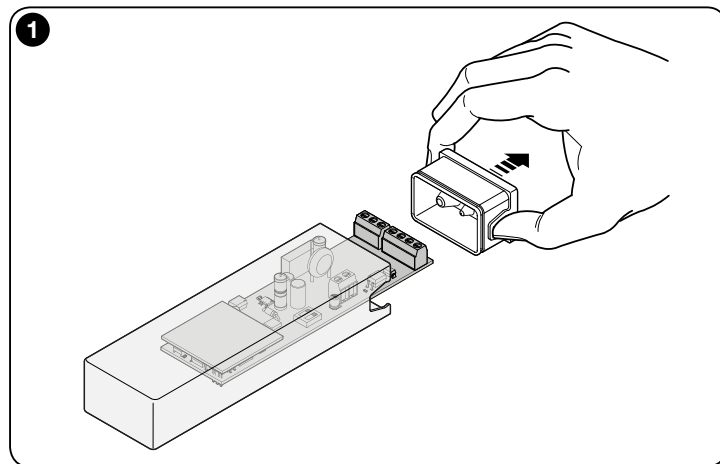

2

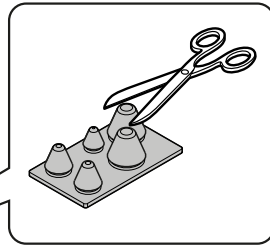
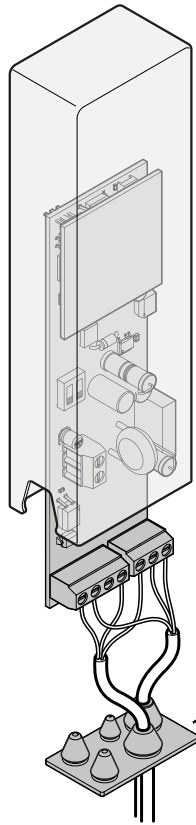

3

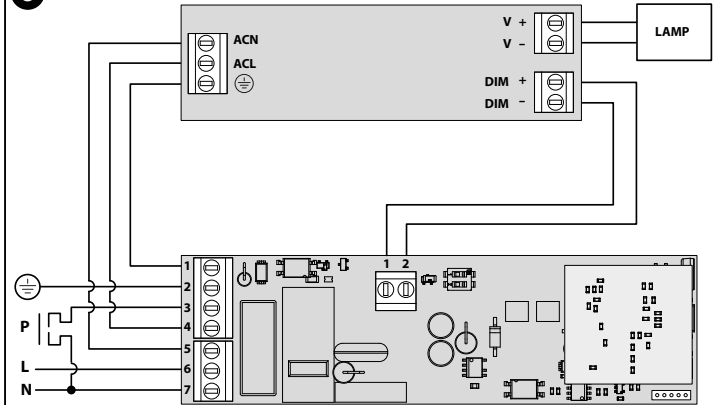

	netspanning	klemmen
Ingang / voeding TTD0110	220 - 240 V AC	7 - fase N 6 - nulleider F 2 - aarde T
Uitgang / voeding externe driver		5 - fase N 4 - nulleider F 1 - aarde T
Uitgang / Externe knop		3 - knop P 7 - nulleider N
	laagspanning	klemmen
Uitgang / externe dri- ver: afstelling 1-10 V of 0-10 V of 2-10 V of PWM	dimmer aangesloten op voeding/driver	1 (-) 2 (+)

Het product omvat twee dipswitches (**afb. 4**) waarmee het type be-
lasting kan worden geselecteerd dat op de uitgang zal worden aan-
gesloten:

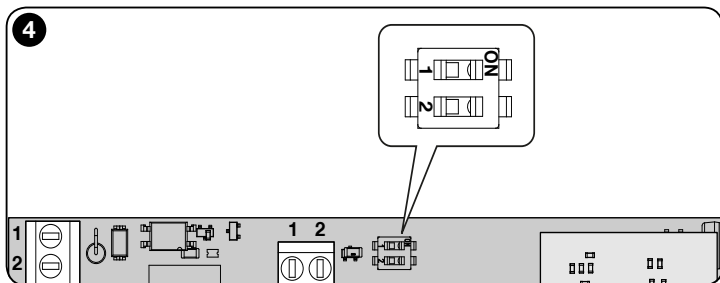

Dip 1	Dip 2	Beschrijving
Off	Off	Uitgang 2-10 V
On	Off	Uitgang 1-10 V
Off	On	Uitgang 0-10 V
On	On	PWM (1k Hz)

Opmerking: controleer het type belasting in de technische kenmerken van de inrichting die aangesloten zal worden.



4 - PROGRAMMERING

De programmering van de TTD0110 moet gebeuren via een in "Procedure 1" opgeslagen zender of via de externe knop.

Er kunnen maximaal 30 zenders in "Procedure 1" of in "Procedure 2" worden opgeslagen om verschillende gedragingen te krijgen:

TABEL 2

Procedure 1: de drie instructies automatisch toewijzen aan de eerste drie toetsen van de zender

Toetsen	Functie
 / ①	Dimmer up
 / ②	Toggle

 / ③	Dimmer down
④ ...	-

Procedure 2: een van de beschikbare instructies vrij koppelen

Functie	Procedure	Beschrijving
Dimmer up	1 maal kort drukken op de toets (< 1 seconde)	De lichtsterkte van de lamp wordt met een klein percentage verhoogd, als deze nog niet op de maximale waarde is ingesteld.
	1 maal langer drukken op de toets (> 1 seconde)	De lichtsterkte van de lamp wordt verhoogd tot de maximale ingestelde waarde wordt bereikt of de toets wordt losgelaten.
Toggle	bij iedere druk op de toets	De dimmer schakelt de aangesloten lichtbron in (On) of uit (Off). Lichtsterktewaarde gekoppeld aan "On": de laatste lichtsterktedrempel die in de dimmer is opgeslagen. De waarde wordt automatisch door de dimmer opgeslagen als de ingeschakelde lamp wordt uitgeschakeld (in dit geval zal de opgeslagen waarde gelijk zijn aan de lichtsterkte van de lamp voordat deze werd uitgeschakeld) of, in elk geval, ongeveer 60 seconden na de laatste verandering in lichtsterkte (in dit geval wordt de laatste lichtsterktewaarde opgeslagen).
Dimmer down	1 maal kort drukken op de toets (< 1 seconde)	De lichtsterkte van de lamp wordt met een klein percentage verlaagd, als deze nog niet op de minimale waarde is ingesteld.
	1 maal langer drukken op de toets (> 1 seconde)	De lichtsterkte van de lamp wordt verlaagd tot de minimale ingestelde waarde wordt bereikt of de toets wordt losgelaten.

Dimmer up Toggle Dimmer down ...	bij iedere druk op de toets	De diverse functies worden afwisselend uitgevoerd.
--	------------------------------------	--

4.1 - Functie "Slider"

Zorgt voor de inschakeling / uitschakeling van de lamp en de dynamische afstelling van de lichtsterkte. Het capacitieve oppervlak fungeert als een cursor (slider):

Procedure	Beschrijving
Korte aanraking van de slider	Instructie met absolute positionering
Schuiven van de slider	Vordering van de instructies voor het afstellen van de lichtsterkte in dynamische modus: verzending van de instructies staat los van de plaats waar de vinger zich bevindt.

4.2 - LED (afb. 5)

De led op het bovenste deel van de TTD0110 voert diverse signaleringen uit, zowel in de programmeringsprocedures als algemene signaleringen:

Knipperiingen	Kleur	Uitvoering	Beschrijving
6	groen	aan het eind van een opslagprocedure van een zender	Het geheugen is vol, de zender kan niet worden opgeslagen.
2	groen	wanneer de dimmer wordt gevoed	Het geheugen is leeg (= geen enkele zender opgeslagen).
2	rood	tijdens eender welke programmeringsprocedure	Er heeft zich een fout voorgedaan.
permanently brandend	blauw	brandt wanneer de voeding / driver wordt geactiveerd	Spanning klemmen 5 en 4



5



De programmeringsprocedures worden in deze handleiding aangeduid aan de hand van pictogrammen, waarvan u de betekenis terugvindt in de onderstaande tabel:

LEGENDA	
LED: gedrag tijdens de programmeringsprocedures	
Symbol	Beschrijving
	AAN
	UIT
	LANG knipperen
	KORT knipperen
	SNEL knipperen
Overige symbolen	
Symbol	Beschrijving
	VOEDING ONDERBREKEN







	VOEDING INSCHAKELEN
	LAMP AAN
	LAMP UIT
	GEWENSTE WAARDE VOOR DE LICHTSTERKTE VAN DE LAMP
	KORT INDRUKKEN
	DE TOETS VAN DE ZENDER INGEDRUKT HOUDEN
	DE TOETS VAN DE ZENDER LOSLATEN
	DE TOETS VAN DE ZENDER TEGELIJKERTIJD INGEDRUKT HOUDEN
	DE TOETS VAN DE ZENDER TEGELIJKER- TIJD LOSLATEN
	TOETSEN ZENDER
	TOETSEN ZENDER
	DE GEWENSTE TOETS VAN DE ZENDER KORT INDRUKKEN
	BEKIJKEN / KIEZEN
	WACHTEN TOT ...
 2 seconden	EEN SPECIFIEKE TIJD WACHTEN

	DE EXTERNE KNOP KORT INDRUKKEN
	DE EXTERNE KNOP INGEDRUKT HOUDEN
	DE EXTERNE KNOP LOSLATEN

4.3 - Leerprocedure Zenders









4.3.1 - Gebruik "Eerste zender" (geheugen leeg)

Via deze procedure kan in "Procedure 1" een zender aan de dimmer worden gekoppeld.

01.		 2 seconden		2  groene led
02.	binnen 5 seconden	 gedurende 8 seconden		
03.	2  groene led: opslag OK			
	2  rode led: opslag NIET VOLTOOID <i>In dit geval de procedure vanaf het begin herhalen.</i>			



4.3.2 - Gebruik “Overige zenders”: Procedure 1













Via deze procedure kan in “**Procedure 1**” een zender aan de dimmer worden gekoppeld.





01.	NIEUWE zender	 gedurende 8 seconden		1  rode led
02.	OUDE zender al opgeslagen		x 3 	
03.	NIEUWE zender	 gedurende 5 seconden		
04.	2  groene led: opslag OK 2  rode led: opslag NIET VOLTOOID <i>In dit geval de procedure vanaf het begin herhalen.</i>			

4.3.3 - Gebruik “Overige zenders”: Procedure 2

Via deze procedure kan in “**Procedure 2**” een zender aan de dimmer worden gekoppeld.











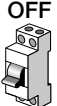





01.	OUDE zender al opgeslagen	 gedurende 8 s		1  groene led
------------	----------------------------------	--	--	--

















02.	OUDE zender al opgeslagen	 gedurende 8 s		2  groene led
03.	OUDE zender al opgeslagen	 de gewenste functie kiezen:		
	Dimmer Up > Toggle > Dimmer Down		x 1 	
	Dimmer Up		x 2 	
	Dimmer Down		x 3 	
	Toggle		x 4 	
	Niveau 1		x 5 	
	Niveau 2		x 6 	
	Niveau 3		x 7 	
	Niveau 4		x 8 	
	UIT		x 9 	

	AAN		x 10 
04.	 5 seconden = 	...  groene led aantal ... knipperingen op basis van gekozen functie	
05.	 gewenste toets van de zender	 groene led	 3 sec. = 
06.	2  groene led: opslag OK		

4.3.4 - Gebruik "Externe knop": Procedure 2

Via deze procedure kan in "Procedure 2" een zender aan de dimmer worden gekoppeld.













01.					 groene led		3 sec. = 	
02.		 groene led		3 sec. = 		 bij 5e		
03.	 de gewenste functie kiezen							
	Dimmer Up > Toggle > Dimmer Down						x 1	

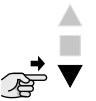

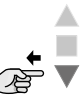
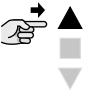

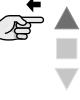
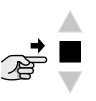
	Dimmer Up	x 2 		
	Dimmer Down	x 3 		
	Toggle	x 4 		
	Niveau 1	x 5 		
	Niveau 2	x 6 		
	Niveau 3	x 7 		
	Niveau 4	x 8 		
	UIT	x 9 		
	AAN	x 10 		
04.	 5 seconden	 groene led aantal ... knipperingen op basis van gekozen functie		
05.	 gewenste toets van de zender	 groene led	 3 sec. = 	
06.	2  groene led: opslag OK			

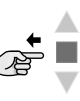
4.4 - Het geheugen wissen

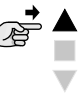
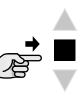



















4.4.1 - Gebruik "Opgeslagen zender"

Met behulp van een in "Procedure 1" opgeslagen zender kan het geheugen geheel of gedeeltelijk worden gewist.

01.			1  groene led	
02.			2  groene led	
03.			3  groene led	
04.			4  groene led	
05.	 de gewenste functie kiezen			
Alleen de zenders wissen				
Alleen de parameters wissen				

	Alleen de zenders en de parameters wissen		
06.	 5 seconden	2  groene led	
	2  rode led: opslag NIET VOLTOOID <i>In dit geval de procedure vanaf het begin herhalen.</i>		

4.4.2 - Gebruik "Externe knop"

01.							3 sec. = 	
02.						bij 2e 		
03.						bij 5e 		
03.	 de gewenste functie kiezen							

	Alleen de zenders wissen		x 1	
	Alleen de parameters wissen		x 2	
	Alleen de zenders en de parameters wissen		x 3	
04.	5 seconden	groene led aantal ... knipperingen op basis van gekozen functie		
05.		groene led	3 sec. =	
06.	2 groene led: opslag OK			

4.5 - Programmering lichtsterkteniveaus

4.5.1 - Gebruik "Opgeslagen zender"

























Deze procedure kan alleen worden uitgevoerd met een zender die al is opgeslagen in "Procedure 1".













Het opgeslagen lichtsterkteniveau kan alleen opnieuw worden opgeroepen nadat het is gekoppeld aan een toets van een zender die in Procedure 2 werd geprogrammeerd.

01.		3 sec.	1 groene led	
-----	--	--------	---------------	--

02.		3 sec.	2 groene led		
03.	Met behulp van de toetsen ▲ - ▼ de lichtsterkte regelen	lichtsterktewaarde van het gewenste licht	10 seconden	2 groene led	
04.	de gewenste functie kiezen				
	Niveau 1		=	2 groene led	
	Niveau 2		=	2 groene led	
	Niveau 3		=	2 groene led	
	Niveau 4		=	2 groene led	

4.5.2 - Gebruik "Externe knop"





01.						3 sec. = 	
02.				3 sec. = 			
03.						bij 2e 	
04.	De lichtsterkte van de lamp op de gewenste waarde instellen met behulp van de externe knop:						
	1^ langer drukken op de externe knop = de lichtsterkte neemt toe tot de knop wordt losgelaten						
	2^ langer drukken op de externe knop = de lichtsterkte neemt af tot de knop wordt losgelaten						
	LET OP!  = functie "Toggle" (ON/OFF)						
05.		lichtsterktewaarde van het gewenste licht		= 2			5 seconden
06.		het gewenste niveau kiezen					

	Niveau 1	x 1 		
	Niveau 2	x 2 		
	Niveau 3	x 3 		
	Niveau 4	x 4 		
07.	 5 seconden	 groene led +  aantal ... knipperingen op basis van gekozen niveau		
08.		 groene led	 3 sec. = 	
09.	2  groene led: opslag OK			

4.6 - Programmering blokkering of deblokkering van het geheugen

4.6.1 - Gebruik "Opgeslagen zender"

Deze procedure kan alleen worden uitgevoerd met een zender die al is opgeslagen in "Procedure 1".

01.			1  groene led	
-----	---	---	--	---

02.			2 groene led	
03.			3 groene led	
04.			4 groene led	
05.	de gewenste functie kiezen			
	Geheugen blokkeren	2 ;		
	Geheugen deblokkeren	2 ;		

4.6.2 - Gebruik "Externe knop"

01.	OFF 		ON 			3 sec. =	
			groene led				

02.		groene led		3 sec. =			bij 2e
03.		groene led		3 sec. =			bij 2e
04.	de gewenste functie kiezen						
	Geheugen blokkeren						x 1
	Geheugen deblokkeren						x 2
05.		5 seconden		groene led +	aantal ... knipperingen op basis van gekozen functie		
06.		groene led		3 sec. =			
07.	2 groene led: opslag OK						

5 - Vervangen van de batterijen

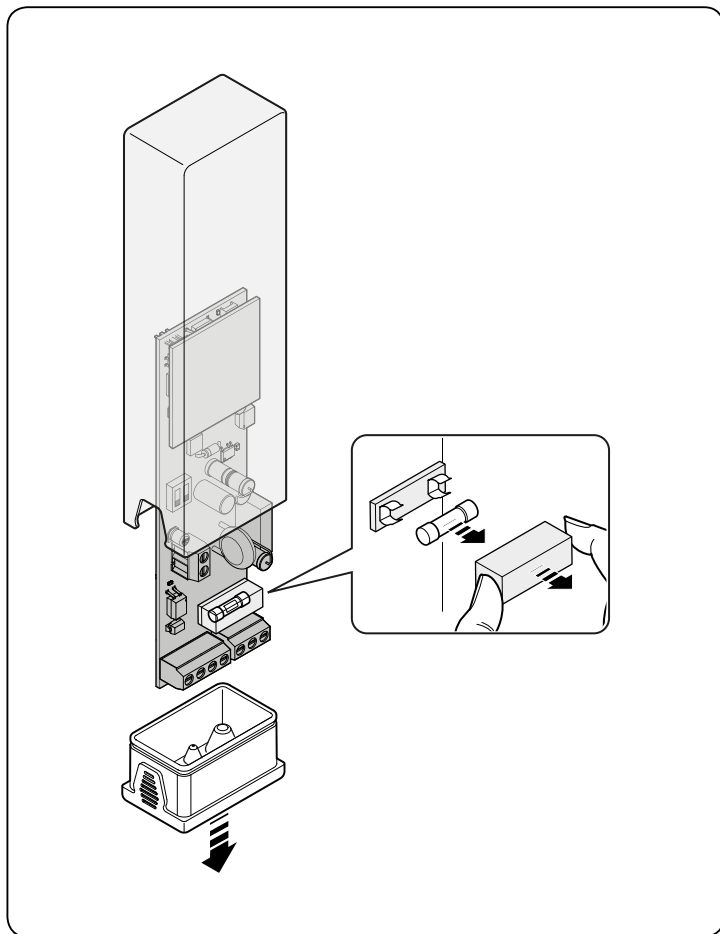

6 - TECHNISCHE KENMERKEN

Ingang	
Spanning	230 V AC \pm 10%
Frequentie	50 Hz
Opgenomen vermogen (in stand-by)	550 mW
Uitgang	
Spanning	230 V AC \pm 10%
Frequentie	50 Hz
Max. aanloopstroom	80 A
Omgeving	
Werkingstemperatuur	-40 + 55° C
Opslagtemperatuur	-40 + 70° C
IP	54
Afmetingen	43 x 25 x 150 mm
Gewicht	100 g

7 - AFDANKING VAN HET PRODUCT

Zoals ook voor de installatiehandelingen geldt, moeten de handelingen voor afdanking aan het einde van de levensduur van dit product door gekwalificeerd personeel worden uitgevoerd. Dit product bestaat uit verschillende soorten materialen: sommige kunnen gerecycled worden, andere moeten afgedankt worden. Informeer u over de methoden voor recycling of afdanking die voorzien zijn in de voorschriften die in uw regio voor deze productcategorie gelden.

Let op! – Bepaalde onderdelen van het product kunnen verontreinigende of gevaarlijke stoffen bevatten die bij aanraking met het milieu schadelijke gevolgen voor het milieu of de volksgezondheid kunnen hebben.



Zoals door het symbool hiernaast wordt aangegeven, is het verboden dit product met het huishoudelijk afval weg te gooien. Pas dus “gescheiden afvalinzameling” voor afdanking toe, volgens de methodes voorzien in de voor uw regio geldende voorschriften, of lever het product weer in bij de verkoper op het moment dat u een nieuw gelijksoortig product aanschaft.

Let op! – De plaatselijke regelgeving kan zware straffen voorzien in geval van illegale dumping van dit product. Het verpakkingsmateriaal moet volgens de plaatselijk geldende voorschriften verwerkt worden.



Nice

Nice SpA
Oderzo TV Italia
info@niceforyou.com

www.niceforyou.com