

STOBAG



NYON

The all-weather roof for those with the highest standards.



reddot award 2018
winner



NYON GP3100 | GP4100 / GP4200 PLUS



GP3100 Optional underglass shading



Optional LED lighting strips



GP4100 PLUS with overglass awning

Product benefits NYON

- Elegant all-weather roof
- Narrow rafters provide an unobstructed view of the sky
- STOBAG EXCLUSIVE: Frame and glass statics are tested according to EN, thus expensive static calculations are omitted
- Furniture is protected even in the rain
- The roof water is not visibly drained through the supports
- The glass roof can be extended modularly at any time
- Quick and easy installation
- Roof pitch from 3° to 15°

Options:

- Overglass shading ARNEX PS8000
- Side/front shading
- Side/front glazing
- LED lighting with spots or strips
- Large support spacing possible – due to reinforced water channel

Technical dimensions in millimetres

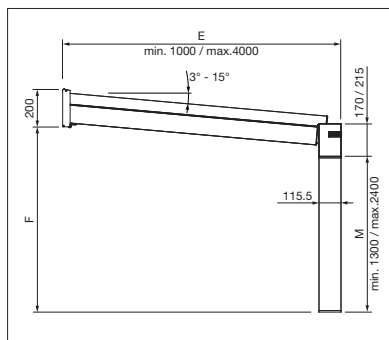

Side view

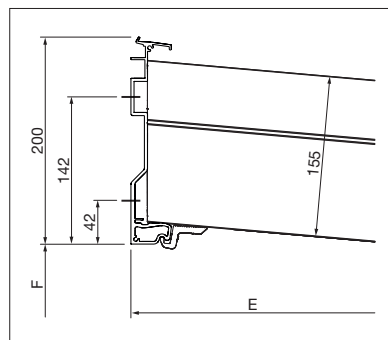

Wall connection

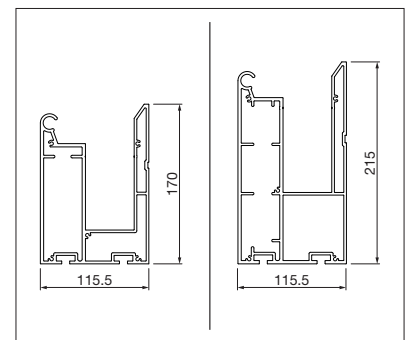

Water channel small/large



GP4200 PLUS Crossbeam repositioned



Special designs

GP3100



reddot award 2018
winner

- Winner of the Red Dot Award 2018
- Snow loads of up to max. 200 kg/m², can be adapted to local conditions
- Optional underglass shading ARNEX PS2500



GP4100 | GP4200 PLUS

- Winner of the GERMAN DESIGN AWARD 2020
- Type NYON PLUS GP4100 – Water channel on the front side
- Design NYON PLUS GP4200 – Cross beam recessed
- Snow loads of up to max. 600 kg/m²; can be adapted to local conditions
- Easy maintenance
- Special designs possible
- Special reinforcement for installation on insulated facades (house corner)



min. 100 cm
max. 2400 cm



min. 100 cm*
max. 400 cm

*with underglass shading 120 cm



min. 50 cm
max. 2400 cm



min. 100 cm
max. 450 cm / GP4100
max. 550 cm / GP4200

STOBAG EXCLUSIVE

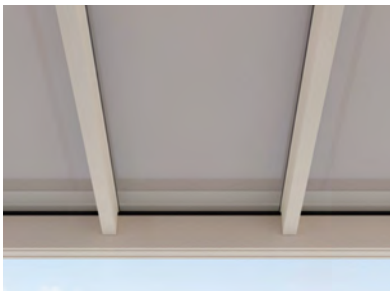

GAPLESS SHADING

Thanks to continuous shading and a screen at the front, there is no intrusive light gap, which creates a pleasant and glare-free ambience.

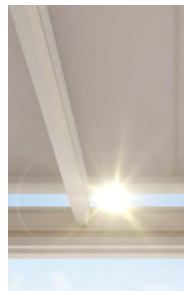

Conventional
product solution

STOBAG EXCLUSIVE

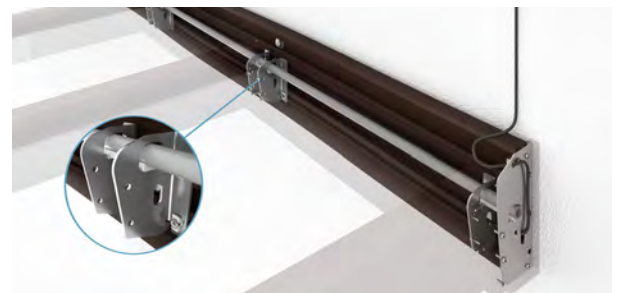

WALL CONNECTION PATENTED

The floating guide tube makes it easy to compensate for unevenness in the wall. This allows a simplified, time-saving installation and minimizes the effort for the installation work. In addition, the angle of inclination can be adjusted or corrected on site.



FABRICS

Choose from a comprehensive range of materials and colours.



ELECTRICS

More convenience thanks to the automated control and lighting systems.



**WE CREATE FAVOURITE OUTDOOR PLACES
WHERE YOU WON'T CARE ABOUT THE WEATHER.**